

पुनर्पुष्ट 2014
Reaffirmed 2014

पुनर्पुष्ट 2009
Reaffirmed 2009

IS 7907 (Part 1) : 2004

भारतीय मानक
सर्पित विस्तार स्प्रिंग
भाग 1 वृत्ताकार खंड तार एवं सरियों से निर्मित
स्प्रिंगों के डिजाइन और परिकलन
(पहला पुनरीक्षण)

Indian Standard

HELICAL EXTENSION SPRINGS

PART 1 DESIGN AND CALCULATION FOR SPRINGS MADE FROM
CIRCULAR SECTION WIRE AND BAR

(First Revision)

ICS 21.160



© BIS 2004

BUREAU OF INDIAN STANDARDS
MANAK BHAVAN, 9 BAHADUR SHAH ZAFAR MARG
NEW DELHI 110002

October 2004

Price Group 9

09

FOREWORD

This Indian Standard (Part 1) (First Revision) was adopted by the Bureau of Indian Standards, after the draft finalized by the Automotive Springs and Suspension Systems Sectional Committee had been approved by the Transport Engineering Division Council.

This standard was originally published in 1976. This revision incorporates a number of changes which were felt necessary as a result of further experience gained in the manufacture, use of compression spring, revision of base standard and due to other developments in this field.

The following technical changes have been incorporated:

- a) Values of various spring parameters for cold formed and hot formed extension springs (*see* Table 1).
- b) Design stresses/modes of loading is elaborated.
- c) Information provided on the modulus of elasticity and rigidity as a function of operating temperature for materials specified.

This standard is one of the series of standards on design, calculation and specifications of helical coiled springs. Other standards in this series are:

<i>IS No.</i>	<i>Title</i>
7906	Helical compression springs:
(Part 1) : 1997	Design and calculations for springs made from circular section wire and bar
(Part 2) : 1975	Specification for cold coiled springs made from circular section wire and bar
(Part 3) : 1975	Data sheet for specifications for springs made from circular section wire and bar
(Part 4) : 1987	Guide for selection of standard cold coiled springs made from circular section wire and bar
(Part 5) : 1989	Specification for hot coiled springs made from circular section bars (<i>second revision</i>)
7907	Helical extension springs:
(Part 2) : 1976	Specification for cold coiled springs made from circular section wire and bar
(Part 3) : 1975	Data sheet for specification for springs made from circular section wire and bar
(Part 4) : 1987	Guide for selection of standard cold coiled springs made from circular section wire and bar

The object of the present standard is to provide an accurate and rapid method of determining the dimensions of helical extension springs made from circular section wire and bar. It can be used both for calculating the specification from available data and also for checking purposes. Worked examples have been included to promote understanding of the calculation methods.

The main requirements to be satisfied in the design of helical springs are maximum possible dependability and life combined with lowest possible weight and cost. At the same time the expenditure of time and effort involved in the calculation procedure needs to be reduced as much as possible. Two nomograms have been incorporated in the standard which can be used as a rapid method of arriving at provisional figures.

In spring calculations a distinction is made between springs subjected to a static or infrequently varying load and springs subjected to alternating load.

The cross-section of the wire or bar of which a helical spring is made is stressed mainly in torsion. In the calculations, therefore, the shear stresses likely to occur under load are compared with the permissible shear stresses. The stressing imposed on the spring, consisting in fact of an overwhelmingly torsional element and a negligibly small bending element, is more severe on the inside of the coil than on the outside. This stress maximum is taken into account in the calculation by introducing stress correction factor, k . Tests have shown, however, that stress correction factor k can be omitted in calculations concerned with springs subjected to a static or infrequently varying load.

(Continued on third cover)

Indian Standard

HELICAL EXTENSION SPRINGS

PART 1 DESIGN AND CALCULATION FOR SPRINGS MADE FROM
CIRCULAR SECTION WIRE AND BAR

(First Revision)

1 SCOPE

This standard (Part 1) lays down calculations for design of helical extension springs made from circular section wire and bar.

1.1 It applies to cold and hot coiled springs loaded in the direction of the spring axis and operated at normal room temperature. For operations at considerably higher or lower temperatures, spring manufacturer should be consulted.

The values specified in Table 1 shall also apply.

Table 1 Quality Requirements of Hot and Cold Formed Extension Springs
(Foreword and Clause 1.1)

Sl No.	Spring Parameter	Cold Formed Extension Springs	Hot Formed Extension Springs
(1)	(2)	(3)	(4)
i)	Diameter of wire or rod, d	Not exceeding 17 mm	From 10 to 35 mm
ii)	Mean coil diameter, D	Not exceeding 160 mm	Not exceeding 300 mm
iii)	Number of active coils, n	Not less than 3	Not less than 3
iv)	Spring index, w	From 4 to 20	From 4 to 12

2 REFERENCES

The following standards contain provisions which through reference in this text, constitute provisions of this standard. At the time of publication, the editions indicated were valid. All standards are subject to revision, and parties to agreements based on this standard are encouraged to investigate the possibility of applying the most recent editions of the standards indicated below:

IS No.	Title
3195 : 1992	Steel for the manufacture of volute and helical springs (for railway rolling stock) (<i>third revision</i>)
3431 : 1982	Steel for the manufacture of volute, helical and laminated springs for automotive suspension (<i>second revision</i>)

IS No.	Title
4076 : 1983	Hard brass wires for springs and other special purposes (<i>first revision</i>)
4454	Specification for steel wires for cold formed springs:
(Part 1) : 2001	Patented and cold drawn steel wires — Unalloyed (<i>third revision</i>)
(Part 2) : 2001	Oil hardened and tempered spring steel wire and valve spring wire — Unalloyed (<i>second revision</i>)
(Part 4) : 2001	Stainless spring steel wire for normal corrosion resistance (<i>second revision</i>)
7608 : 1987	Phosphor bronze wire for general engineering purposes (<i>first revision</i>)
7811 : 1985	Phosphor bronze rods and bars (<i>first revision</i>)
7814 : 1985	Phosphor bronze sheet and strip (<i>first revision</i>)
7907	Helical extension springs:
(Part 2) : 1976	Specification for cold coiled springs made from circular section wire and bar
(Part 3) : 1975	Data sheet for specification for springs made from circular section wire and bar

3 SYMBOLS

Following symbols and units shall apply (*see Fig. 1*).

A	= work done by spring, mJ;
D_o	= outside diameter of coil, mm;
D_i	= inside diameter of coil, mm;
D_m	= $\frac{D_o + D_i}{2}$ mean diameter of coil, mm;
G	= modulus of rigidity of spring material, N/mm ² ;
L_0	= unloaded length of spring (in the case of springs provided with loops or tapered-in hooks, this distance is measured from inner edge to inner edge of the loops or hooks under loop length), mm;

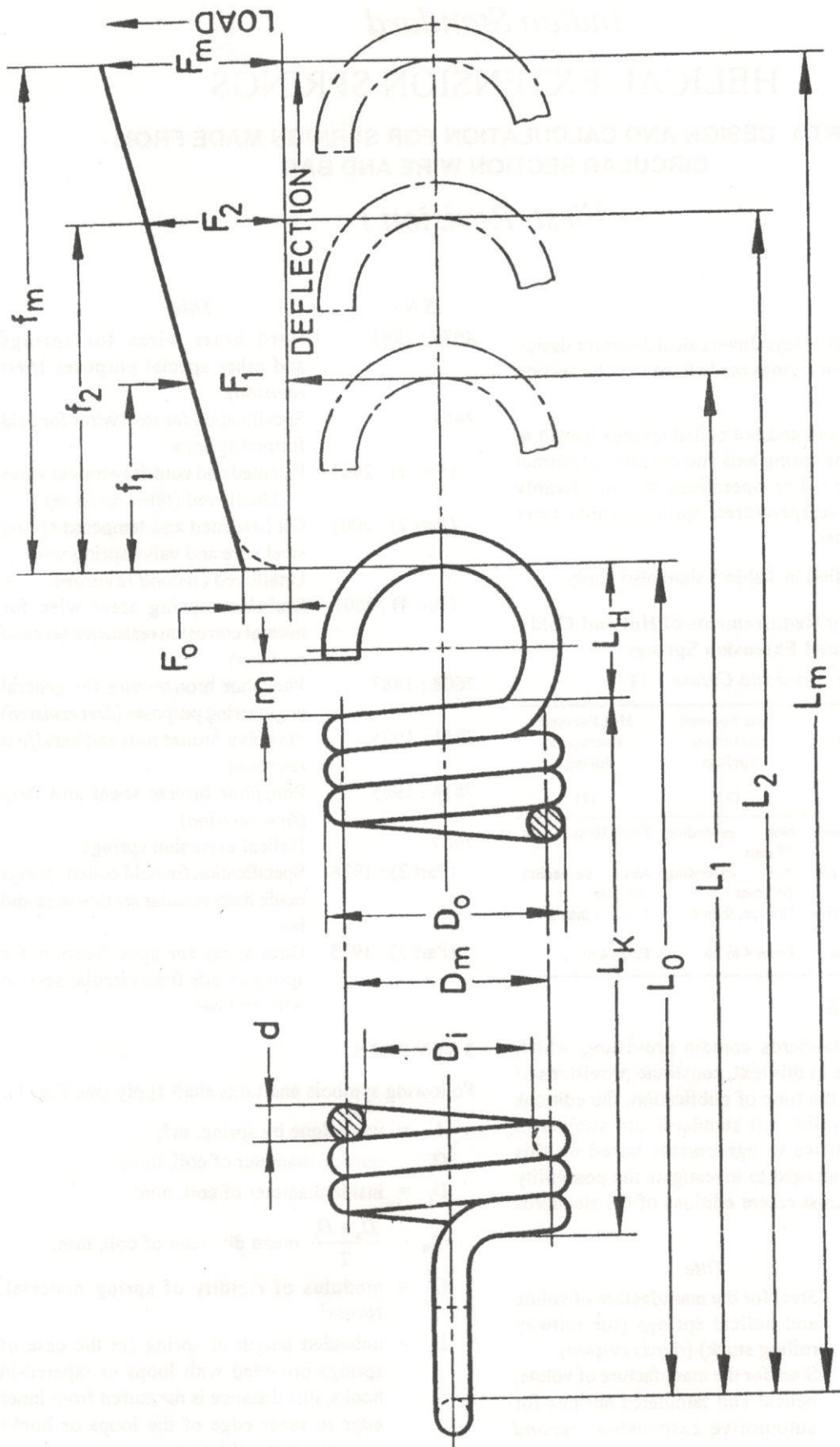

FIG. 1 THEORETICAL EXTENSION SPRING DIAGRAM FOR CALCULATION AND DESIGN SPRING CHARACTERISTICS DIAGRAM ACCORDING TO IS : 7907 (Part 2)

L_1 to L_m = load lengths, measured from inner edge to inner edge corresponding to the axial loads F_1 to F_m , mm;

L_H = distance of inside edge of the hook from the body of spring, mm;

L_k = body length when not loaded but subject to initial tension, mm;

L_m = maximum allowable test length of spring, mm;

F_0 = initial tension, N;

F_1 to F_m = axial loads including initial tension F_0 , corresponding to the load lengths L_1 to L_m , N;

F_m = maximum permissible axial load corresponding to load length L_m , N;

S_c = $\frac{\Delta F}{\Delta f}$ = Spring rate, N/mm;

d = wire or bar diameter, mm;

f_1 to f_m = deflections corresponding to the axial loads F_1 to F_m , mm;

h = stroke (difference yielded by two deflections or two load lengths), mm;

i_t = number of working coils;

i_g = total number of coils;

= i_t + Number of coils made non-working by tapered-in or screwed-in end fittings;

k = stress correction factor, depending on the coil ratio w . In springs subjected to alternating load the stress correction factor k takes account of the non-uniform shear stress distribution over the wire cross-section resulting from the curvature of the wire (see 5);

m = hook opening width, mm;

n = load cycle frequency, Hz;

t = maximum working temperature, °C;

w = $\frac{D_m}{d}$ = coil ratio;

R_m = ultimate tensile strength of the material, N/mm²;

R_s = uncorrected shear stress, N/mm²;

R_{s0} = initial shear stress, N/mm²;

R_{s1} to R_{sm} = shear stress corresponding to the axial loads F_1 to F_m for springs; subjected to a static or infrequently varying load, N/mm²;

R_{sp} = permissible shear stress, N/mm²;

R_k = corrected shear stress taking account of the influence of coil; curvature by means of stress correction factor k , N/mm²;

R_{k1} to R_{km} = corrected shear stress values corresponding

to axial loads F_1 to F_m ; for springs subjected to alternating load, N/mm²; and

R_{kh} = stress range corresponding to stroke h (amplitude of stress), N/mm².

4 DESIGN STRESSES

Prior to designing springs, it shall be specified whether they will be subjected to static loading, moderate fatigue conditions or fatigue loading.

4.1 Static Loading and Moderate Fatigue Conditions

- Springs shall be deemed to be subject to static loading where such loading does not change over time.
- Springs shall be deemed to be subject to moderate fatigue conditions where the loading changes over time but the magnitude of mean fatigue stress is negligible (that is, it does not exceed a value of 0.1 times the torsional elastic limit), or where the loading changes over time and the magnitude of mean fatigue stress is higher than above, but the number of cycles to which they are exposed does not exceed 10^4 .

4.2 Fatigue Loading

- Springs shall be deemed to be subject to fatigue loading where the loading changes over time and the number of cycles to which they are exposed exceeds 10^4 , at constant or fluctuating mean fatigue stresses exceeding 0.1 times the torsional elastic limit.
- Depending on the specified number of cycles to failure, N , a distinction shall be made between:
 - springs with a high endurance life, that is those which are able to withstand at least 10^7 cycles, where the mean fatigue stress is lower than the torsional elastic limit; and
 - springs with a limited endurance life, that is those which are able to withstand less than 10^7 cycles, where the mean fatigue stress exceeds the torsional elastic limit but is lower than the short-term fatigue strength.
- In the case of springs subjected to fluctuating mean fatigue stresses or moderate stresses whose maximum values are higher than the torsional elastic limit, their endurance life can only be estimated with the aid of the damage accumulation hypothesis and shall be established more accurately by means of fatigue testing in service.

5 SPRING DESIGN FORMULAE

5.1 Shear Stresses

$$R_s = \frac{8 \times D_m \times F}{\pi d^3} \quad \dots(1)$$

$$R_s = \frac{G \times d \times f}{\pi i_t \times (D_m)^2} \quad \dots(2)$$

$$R_k = k \times \frac{8 \times D_m \times F}{\pi d^3} \quad \dots(3)$$

$$R_k = k \times \frac{G \times d \times f}{\pi i_t \times (D_m)^2} \quad \dots(4)$$

5.2 Wire or Bar Diameter, d

$$d = \sqrt[3]{\frac{8 \times F \times D_m}{\pi R_s}} = \sqrt[3]{k \times \frac{8 \times F \times D_m}{\pi R_k}} \quad \dots(5)$$

5.3 Deflection, f

$$f = \frac{8 \times (D_m)^3 \times i_t \times F}{G \times d^4} \quad \dots(6)$$

In the case of extension springs with initial tension the difference $(F - F_0)$ shall be substituted for F .

5.4 Number of Working Coils, i_t

$$i_t = \frac{G \times d^4 \times f}{8 \times (D_m)^3 \times F} \quad \dots(7)$$

In the case of extension springs with initial tension, the difference $(F - F_0)$ shall be substituted for F .

The following expression gives an approximate figure for the total number of coils in an extension spring with initial tensions:

$$i_g = \frac{L_k}{d} - 1 \quad \dots(8)$$

For extension springs with open loops as given in Fig. 2 to Fig. 9 and Fig. 14 of IS 7907 (Part 2), $i_t = i_g$. For extension springs with tapered in hooks or with threaded plugs, as shown in Fig. 10 to Fig. 13 of IS 7907 (Part 2), $i_g = i_t +$ number of coils rendered ineffective.

5.5 Load, F

$$F = \frac{G \times d^4 \times f}{8 \times (D_m)^3 \times i_t} \quad \dots(9)$$

In the case of extension springs with initial tension, the difference $(F - F_0)$ must be substituted for F .

5.5.1 Maximum Permissible Load, F_m

$$F = \frac{\pi d^3}{8 \times D_m} \times R_{sp} \quad \dots(10)$$

5.6 Spring Rate, S_c

For extension springs without initial tension:

$$S_c = \frac{\Delta F}{\Delta f} = \frac{F}{f} = \frac{G \times d^4}{8 \times (D_m)^3 \times i_t} \quad \dots(11)$$

For extension springs with initial tension:

$$S_c = \frac{\Delta F}{\Delta f} = \frac{F - F_0}{f} = \frac{G \times d^4}{8 \times (D_m)^3 \times i_t} \quad \dots(12)$$

5.7 Initial Tension, F_0

$$F_0 = F - f \times S_c = F - \frac{G \times d^4 \times f}{8 \times (D_m)^3 \times i_t} \quad \dots(13)$$

5.8 Work Done by Spring, A

$$A = \frac{1}{2} \times (F + F_0) \times f \quad \dots(14)$$

5.9 Modulus of Rigidity, G

The modulus of rigidity for wires for design of spring is as given in Table 2. These values are given at ambient working temperature:

Table 2 Values of Modulus of Rigidity of Spring Wire Materials
(Clause 5.9)

Sl No.	Material	Modulus of Rigidity, G N/mm ²
i)	Patented and cold drawn spring steel wires-unalloyed, Grades 1, 2, 3 and 4 to IS 4454 (Part 1)	81 370
ii)	Oil hardened and tempered spring steel wire and valve spring wire-unalloyed, Grades SW and VW to IS 4454 (Part 2)	81 370
iii)	Alloyed, oil hardened and tempered valve spring wire and spring steel wire for use under moderately elevated temperature, Grades 1S, 2S, 1D and 2D to IS 4454 (Part 2)	81 370
iv)	Hot rolled steel for hot formed springs, Grades 1, 2 and 3 to IS 3431.	80 000
v)	Hot rolled steel for hot formed springs, Grades 98C6, 113C6, 55Si7, 60Si7, 50Cr4V2 and 60Cr4V2 to IS 3195	80 000
vi)	Stainless spring steel wire, Grade 1 to IS 4454 (Part 4)	73 530 (tempered) 69 610 (untempered)

Table 2 (Concluded)

Sl No.	Material	Modulus of Rigidity, $G \text{ N/mm}^2$
vii)	Stainless spring steel wire Grade 2 to IS 4454 (Part 4)	78 430 (tempered) 73 530 (untempered)
viii)	Hard drawn brass wires to IS 4076	35 000
ix)	Phosphor bronze wire for general engineering purposes to IS 7608	42 000
x)	Phosphor bronze rods and bars to IS 7811	42 000
xi)	Phosphor bronze sheet and strip to IS 7814	42 000

NOTE — If the springs are made from wires to IS 4076 and IS 7608/7811/7814 wire diameters not covered in these standards may conform to IS 4454 (Part 1).

5.9.1 For materials other than those specified in 5.9, the values of G shall be obtained from the manufacturer.

6 STRESS CORRECTION FACTOR, k

The curvature of the wire or bar axis brings about an unsymmetric distribution of shear stress over the wire or bar cross-section when an extension spring is extended. The shear stress is higher on the inside of the coil than on the outside (see Fig. 2). This leads to a stress maximum in the inside fibres which may give rise to cracks followed by fatigue failure in the case of alternating load.

6.1 The stress correction factor, k in the design formulae (3) and (4) makes allowance for the stress maximum developed. The design calculations of extension springs subjected to alternating load should, therefore, contain factor, k .

6.2 Correction factor, k depends on the coil ratio, w and increases rapidly as the coil ratio becomes smaller (see Fig. 3). The formula corresponds to that given by Bergstrassar.

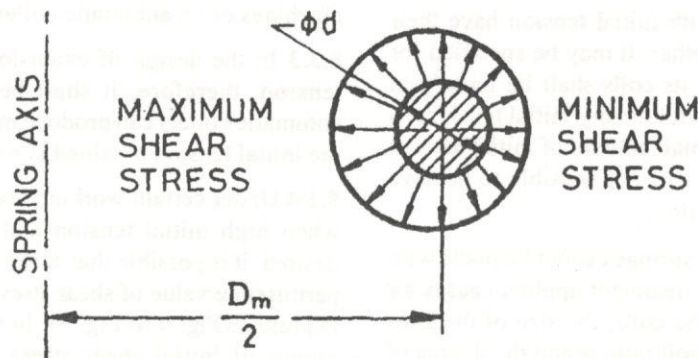

FIG. 2 DISTRIBUTION OF SHEAR STRESSES OVER CIRCUMFERENCE OF WIRE OR BAR CROSS-SECTION OF A HELICAL SPRING

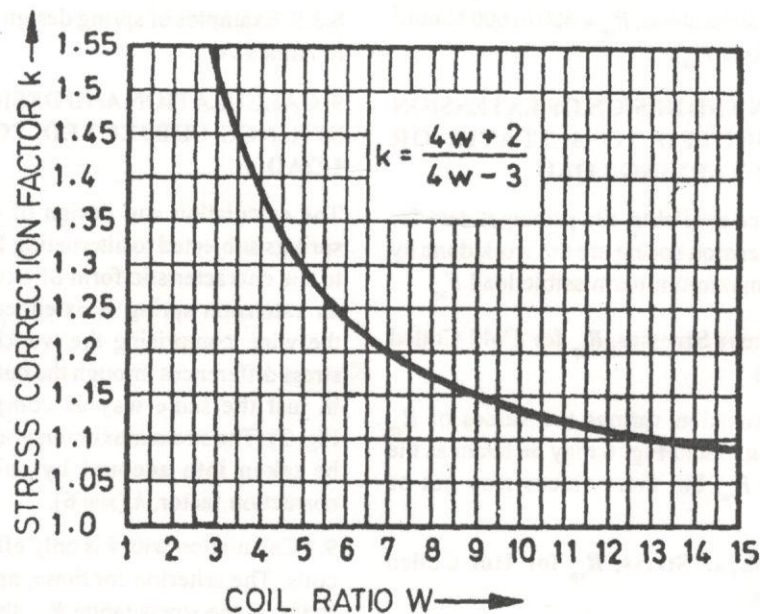

FIG. 3 STRESS CORRECTION FACTOR k AS A FUNCTION OF COIL RATIO W

6.3 In the case of extension springs subjected to a static or infrequently varying load, the local stress maximum is not harmful owing to the supporting effect of less strained regions of the cross-sections. The design calculations of these springs can be carried out without using the stress correction factor, k .

7 INITIAL TENSION, F_0

Initial tension is the load needed to overcome the force which presses coils against one another. Initial tension is introduced by coiling the springs so that the coils exert a certain pressure against each other. The initial tension obtainable in this way is governed primarily by the quality of the wire, the diameter d of the wire, the coil ratio w and the manufacturing method used. In addition, the initial tension depends on the maximum shear stress R_{sm} (see 8.3). The introduction of initial tension F_0 is only practicable for cold coiled extension springs which are not finally hardened.

7.1 Extension springs with initial tension have their coils pressed tightly together. It may be specified for an extension spring that its coils shall lie loosely in contact with each other without any initial tension. In such cases, however, a small amount of initial tension shall be accepted, since it is not possible to achieve uniformly tensionless coiling

7.2 Hot coiled extension springs cannot be made with initial tension. The heat treatment applied causes air gaps to occur between the coils, the size of the gaps being dependent on the coil ratio w and the degree of stressing. For hot coiled extension springs up to 25 mm bar diameter the following approximate figures apply:

Space between coils ≈ 0.5 to 5 mm corresponding to a permissible shear stress, $R_{sp} \approx 400$ to 600 N/mm² (at maximum load F_m).

8 CALCULATION AND DESIGN OF EXTENSION SPRINGS SUBJECTED TO A STATIC OR INFREQUENTLY VARYING LOAD

Apart from the space available, the principal data for the design of an extension spring are the work done by the spring and the maximum permissible load F_m .

8.1 Permissible Shear Stresses, R_{sp} for Cold Coiled Extension Springs

For cold coiled extension springs the values of R_{sp} shown in Fig. 4, Fig. 5 and Fig. 6 may be taken as the basis for the load F_m , but these values may not be exceeded.

8.2 Permissible Shear Stress, R_{sp} for Hot Coiled Extension Springs

For hot coiled extension springs the value $R_{sp} =$

600 N/mm² for the maximum permissible load F_m should not be exceeded.

8.2.1 Hot coiled extension springs may only be used in bar diameters up to 25 mm maximum. For manufacturing reasons it is recommended that the type without loops and with threaded end plugs to IS 7907 (Part 2) should be used.

8.3 Initial Shear Stress, (R_{so})

The stress experienced by cold coiled extension springs as result of the initial tension F_0 is called the initial shear stress, R_{so} .

8.3.1 The attainable initial tension, F_0 depends on the level of the permissible initial shear stress, R_{so} . The latter can be found from Fig. 7 to Fig. 14 for various conditions.

8.3.2 Assuming otherwise similar conditions, the level of the initial shear stress, R_{so} is in turn influenced by the manufacturing method (coiling on hand coiling machines or on automatic coilers).

8.3.3 In the design of extension springs with initial tension, therefore, it shall be borne in mind that automatic coilers can produce more economically, but the initial tension obtained is not high.

8.3.4 Under certain working conditions, for example, when high initial tension and small deflection are desired, it is possible that at the maximum load F_m the permissible value of shear stress, R_{sp} will not be fully exploited (Fig. 4 to Fig. 6). In this case the indicated values of initial shear stress R_{sp} for hand coiling purposes (see Fig. 7, Fig. 9, Fig. 11 and Fig. 13) can be exceeded. The spring manufacturer's advice should be sought where necessary.

8.3.5 Examples of spring design calculations are given in Annex A.

9 CALCULATION AND DESIGN OF EXTENSION SPRINGS SUBJECTED TO ALTERNATING LOAD

The calculation and design of cold coiled extension springs subjected to alternating load is difficult, owing to the characteristic form of extension springs. When an extension spring is extended the cross-section of the wire, comprising the working coils, experiences stress differences through the curvature of the wire axis in just the same way as compression springs (see Fig. 2). The stress maximum arising in this way should be taken into account by calculating with stress correction factor, k (see 6).

9.1 Calculation with k is only effective for the working coils. The criterion for these, apart from the available space, is the stress range R_{kh} , that is, the difference of the shear stresses at F_1 and F_2 .

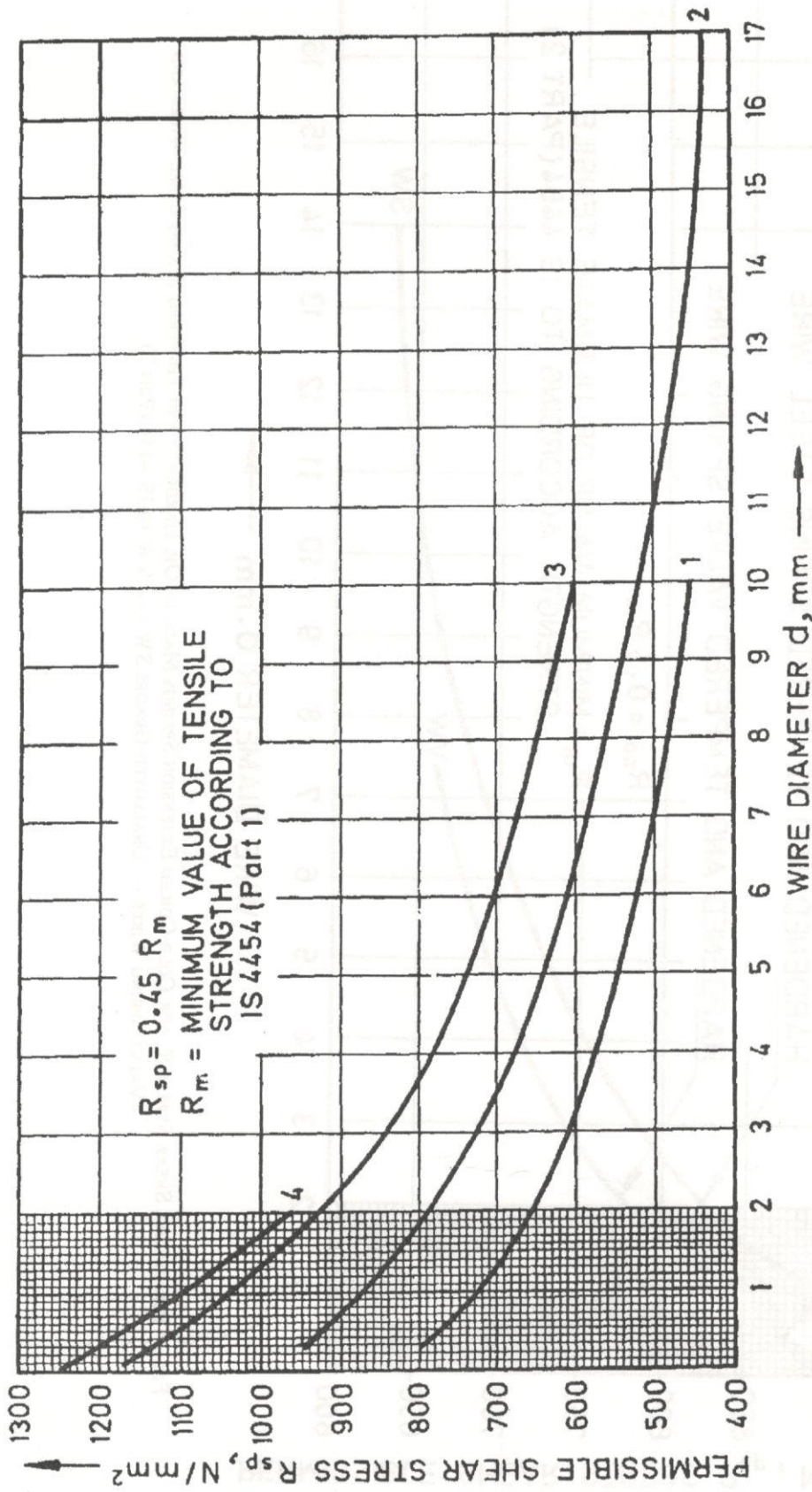

FIG. 4 PERMISSIBLE SHEAR STRESS R_{sp} FOR COLD COILED EXTENSION SPRINGS MADE OF COLD DRAWN AND PATENTED SPRING STEEL WIRES GRADES 1, 2, 3 AND 4 TO IS 4454 (Part 1)

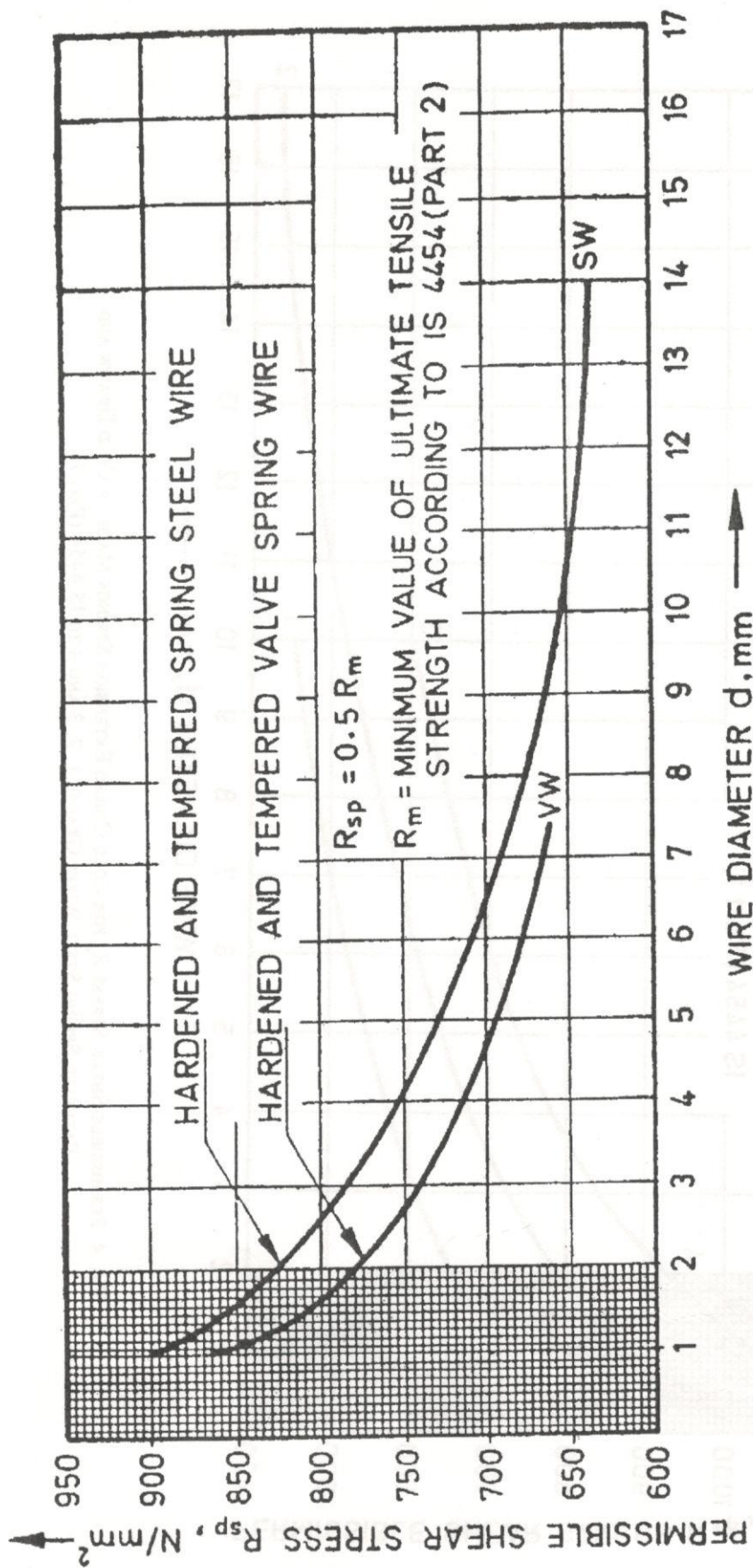

FIG. 5 PERMISSIBLE SHEAR STRESS R_{sp} FOR COLD COILED EXTENSION SPRINGS MADE OF OIL HARDENED AND TEMPERED SPRING STEEL WIRES AND VALVE SPRING WIRES — UNALLOYED GRADES SW AND VW TO IS 4454 (PART 2)

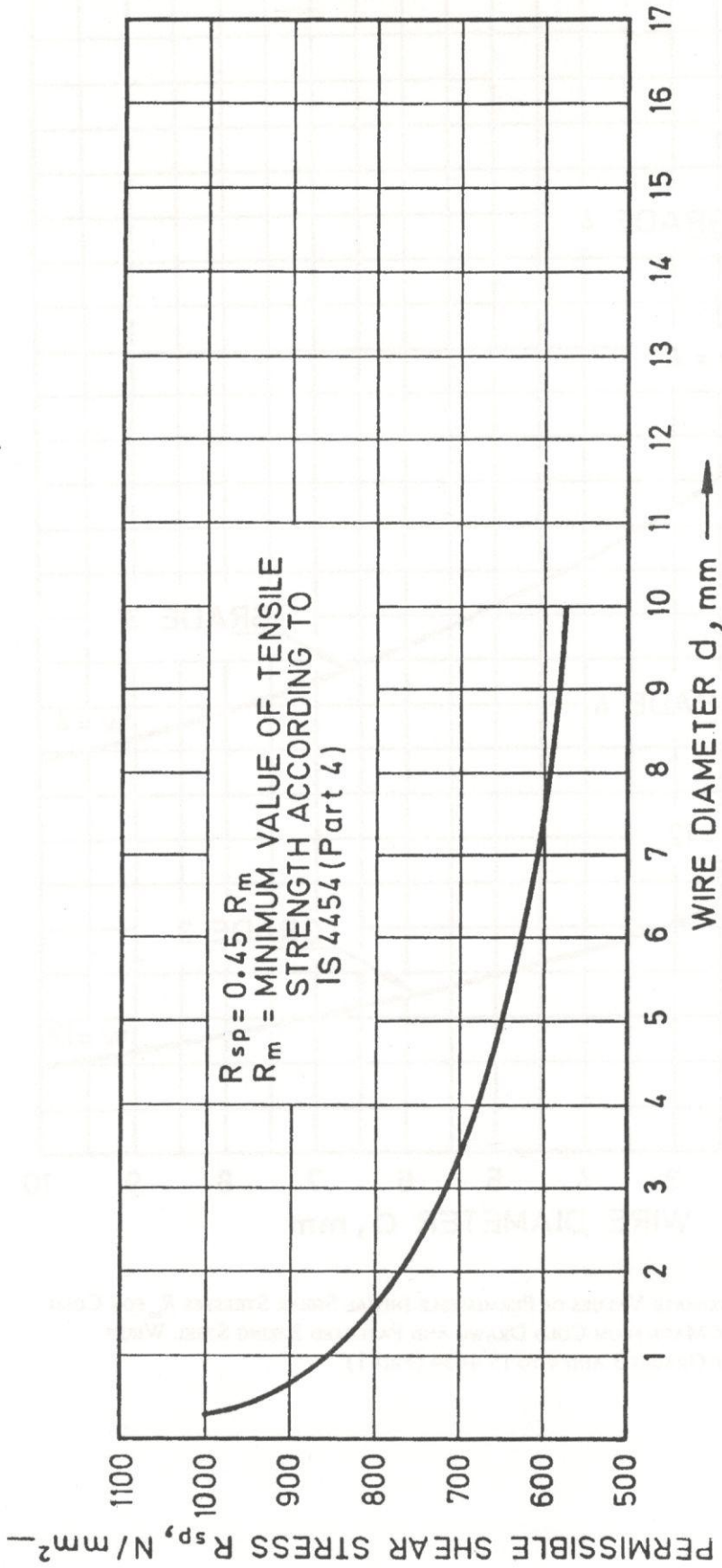

FIG. 6 PERMISSIBLE SHEAR STRESSES R_{sp} FOR COLD COILED EXTENSION SPRINGS MADE OF STAINLESS SPRING STEEL WIRE FOR NORMAL CORROSION RESISTANCE GRADES 1 AND 2 TO IS 4454 (Part 4)

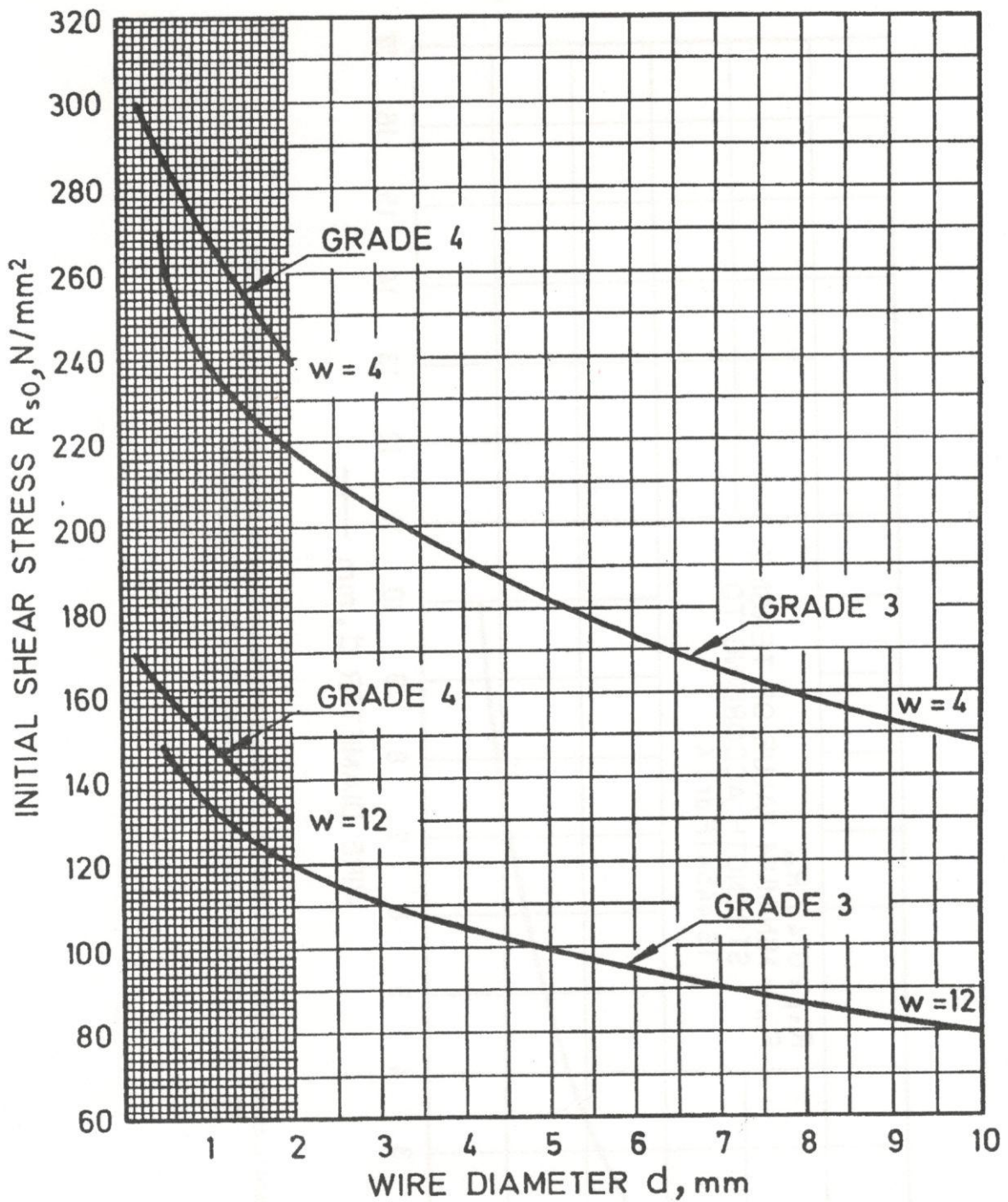

FIG. 7 HAND COILING — APPROXIMATE VALUES OF PERMISSIBLE INITIAL SHEAR STRESSES R_{50} FOR COLD COILED EXTENSION SPRINGS MADE FROM COLD DRAWN AND PATENTED SPRING STEEL WIRES OF GRADES 3 AND 4 TO IS 4454 (Part 1)

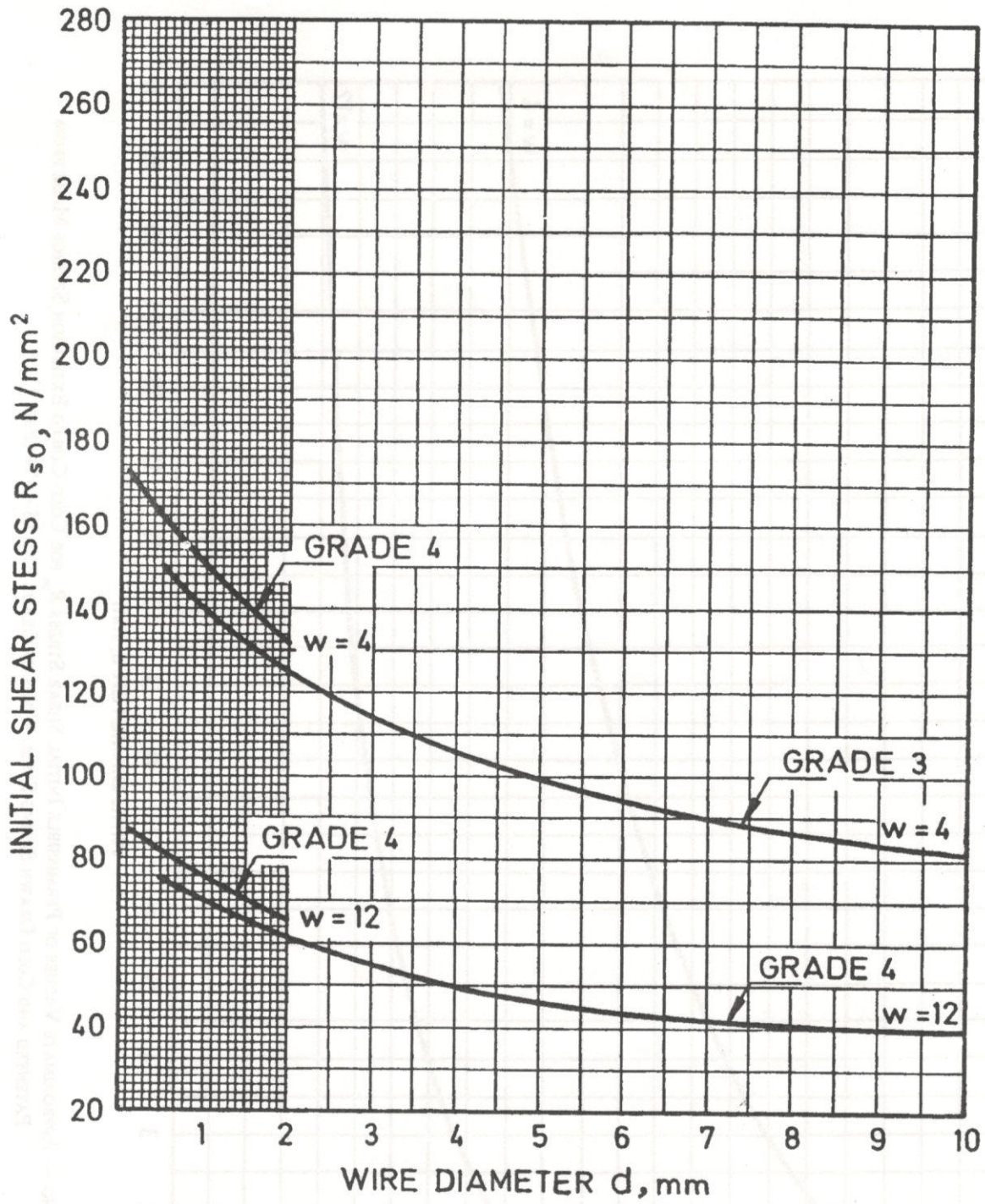

FIG. 8 AUTOMATIC COILING — APPROXIMATE VALUES OF PERMISSIBLE INITIAL SHEAR STRESSES R_{s0} FOR COLD COILED EXTENSION SPRINGS MADE FROM PATENTED AND COLD DRAWN SPRING STEEL WIRES OF GRADES 3 AND 4 TO IS 4454 (Part 1)

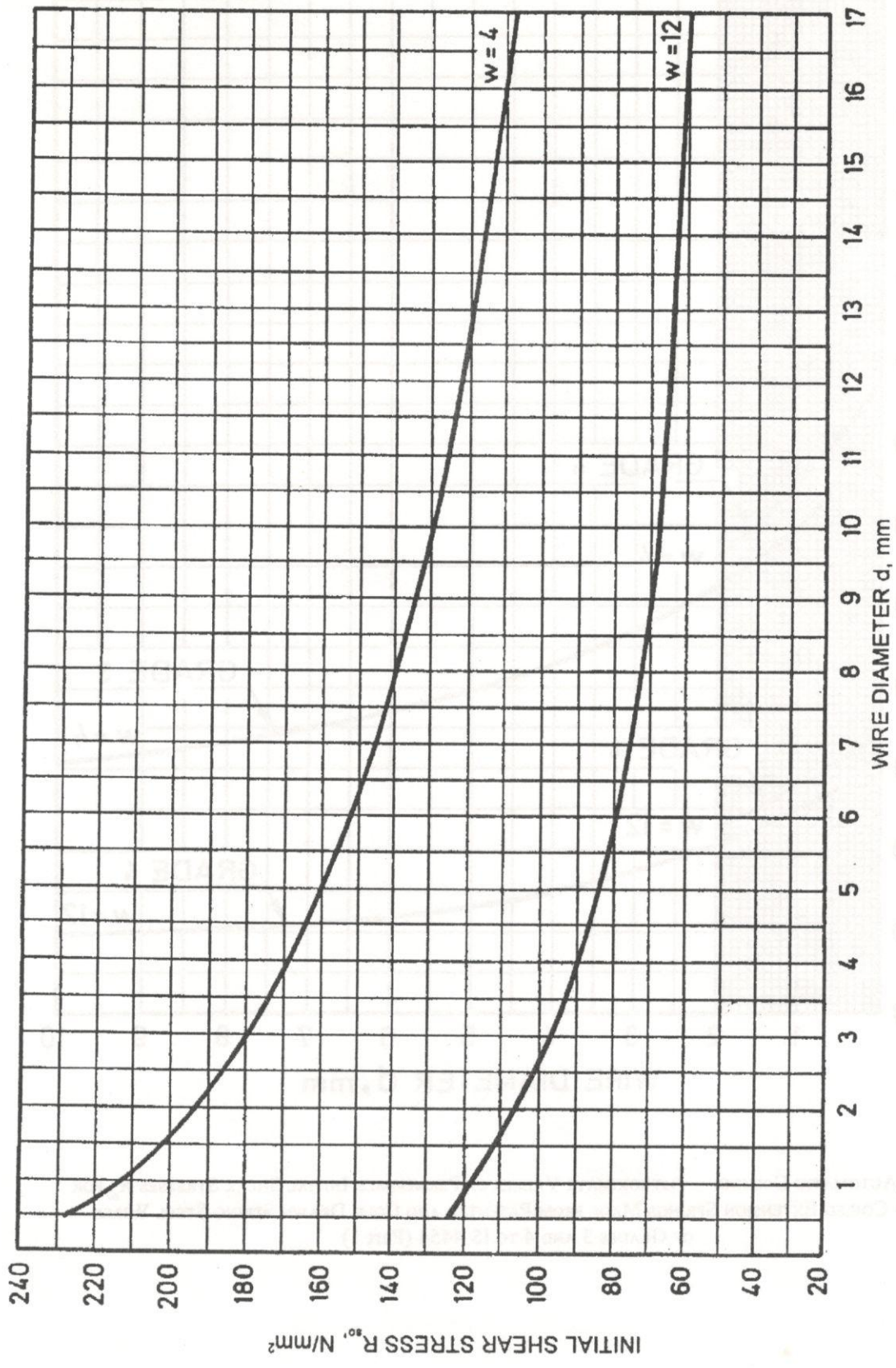

FIG. 9 HAND COILING — APPROXIMATE VALUES OF PERMISSIBLE INITIAL SHEAR STRESS R_{s0} FOR COLD COILED EXTENSION SPRINGS MADE FROM PATENTED AND COLD DRAWN SPRING STEEL WIRES OF GRADE 2 TO IS 4454 (Part 1)

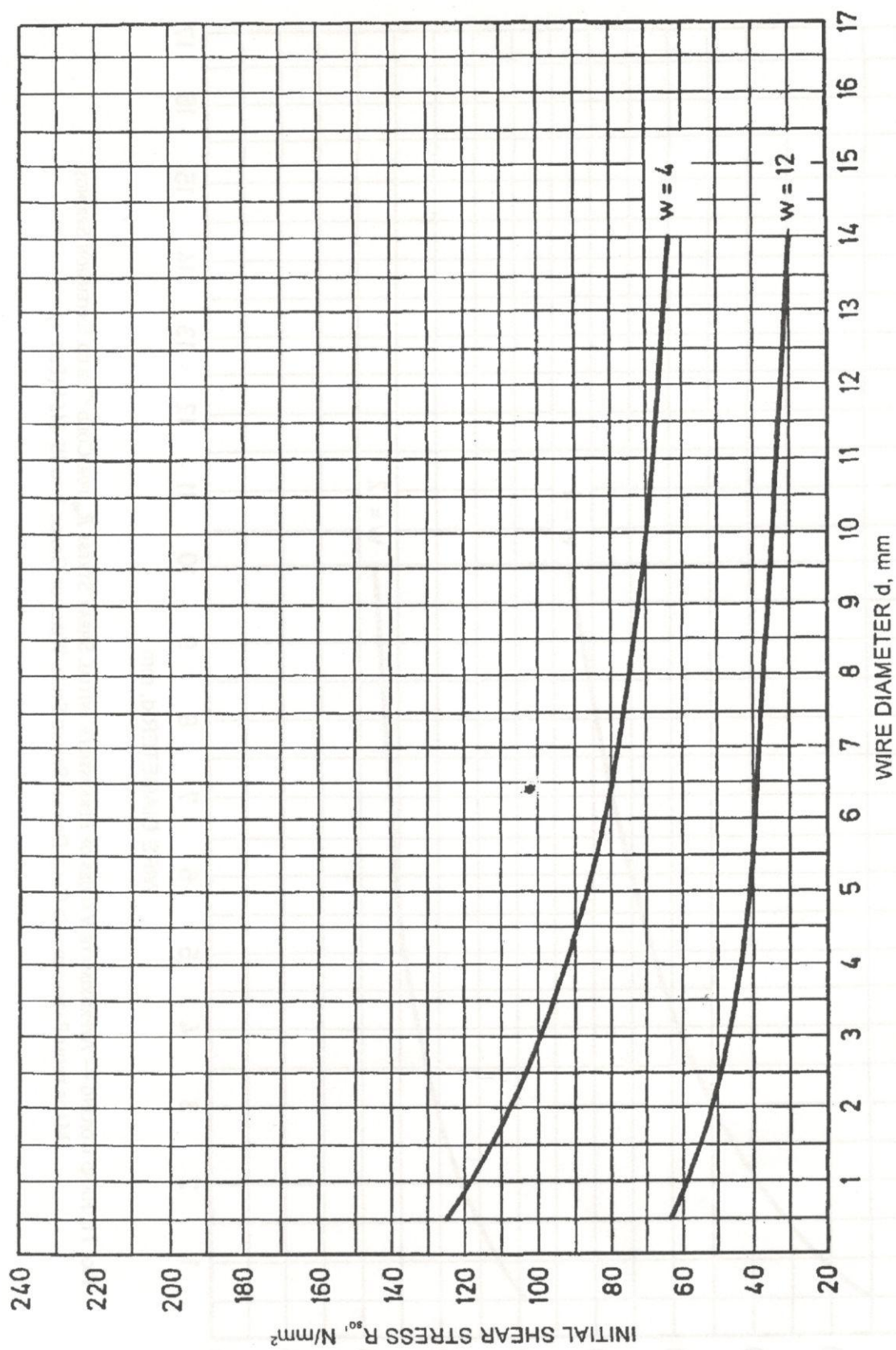

FIG. 10 AUTOMATIC COILING — APPROXIMATE VALUES OF PERMISSIBLE INITIAL SHEAR STRESS R_{90} FOR COLD COILED EXTENSION SPRINGS MADE FROM PATENTED AND COLD DRAWN SPRING STEEL WIRES OF GRADE 2 TO IS 4454 (Part 1)

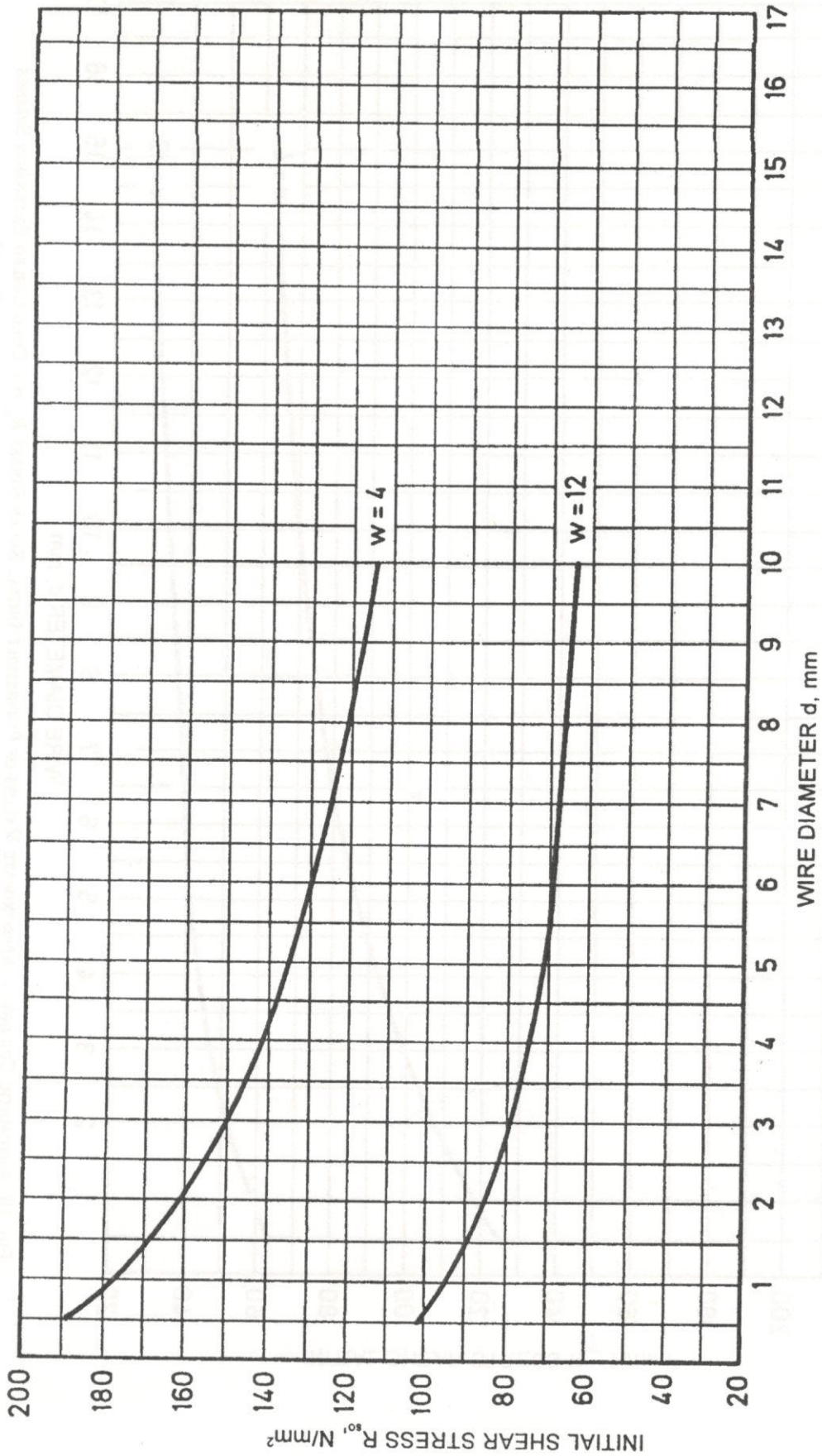

FIG. 11 HAND COILING — APPROXIMATE VALUES OF PERMISSIBLE INITIAL SHEAR STRESS $R_{0.2}$ FOR COLD COILED EXTENSION SPRINGS MADE FROM PATENTED AND COLD DRAWN SPRING STEEL WIRES OF GRADE 1 TO IS 4454 (Part 1)

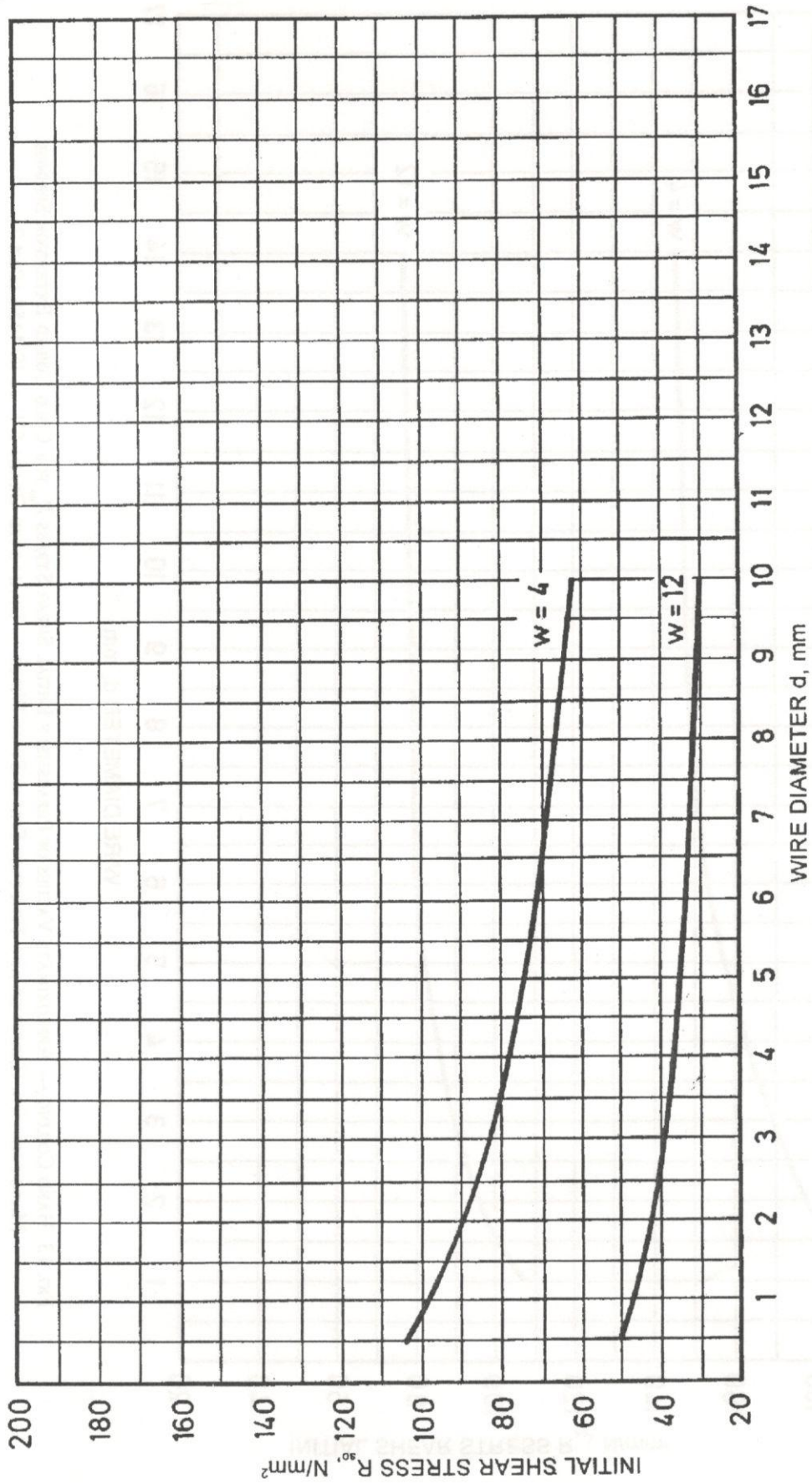

FIG. 12 AUTOMATIC COILING — APPROXIMATE VALUES OF PERMISSIBLE INITIAL SHEAR STRESS R_{30} FOR COLD COILED EXTENSION SPRINGS MADE FROM PATENTED AND COLD DRAWN SPRING STEEL WIRES OF GRADE 1 TO IS 4454 (Part 1)

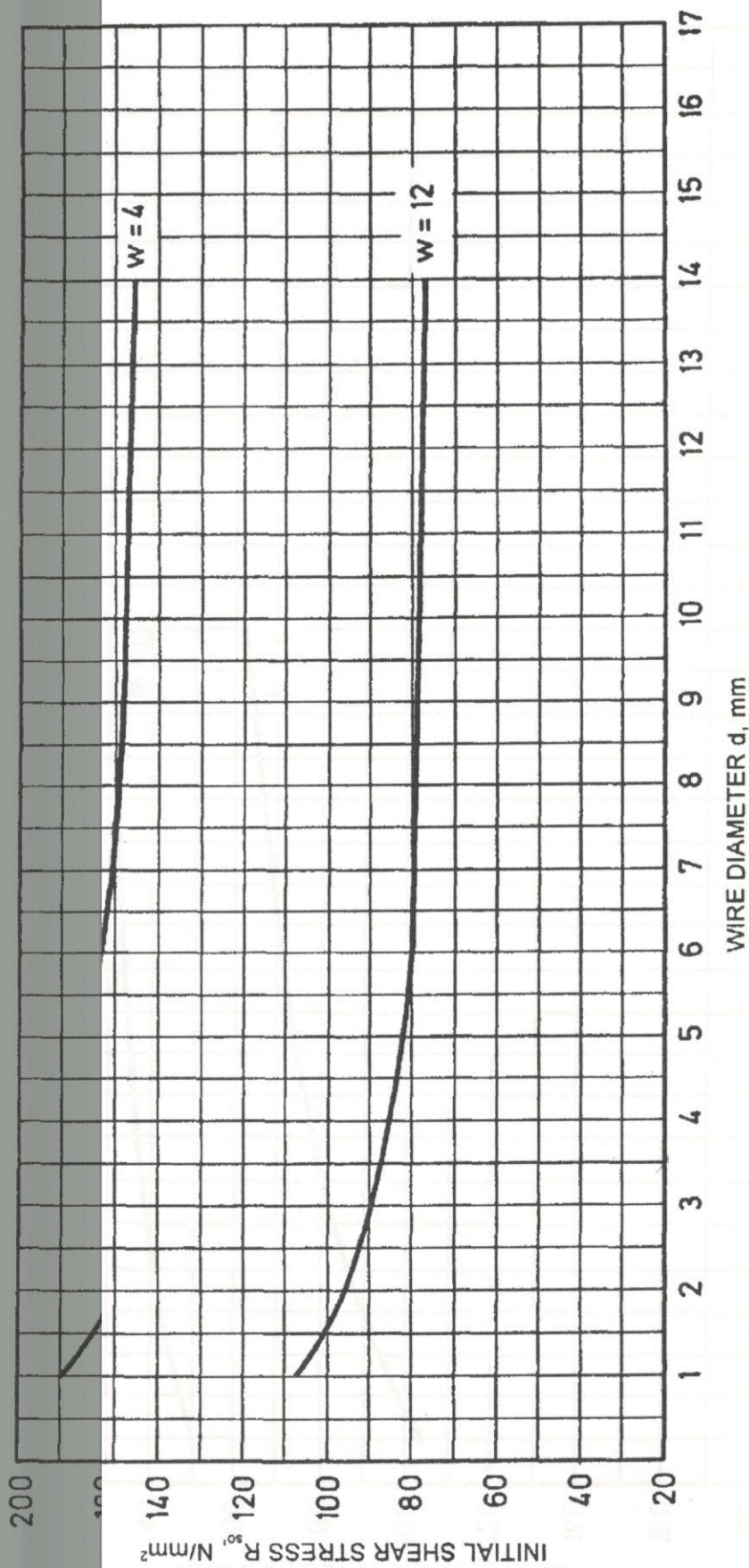

FIG. 13 HAND COILING --- APPROXIMATE VALUES OF PERMISSIBLE INITIAL SHEAR STRESS R_{s0} FOR COLD COILED EXTENSION SPRINGS MADE FROM OIL HARDENED AND TEMPERED SPRING STEEL WIRES --- UNALLOYED GRADE SW TO IS 4454 (Part 2)

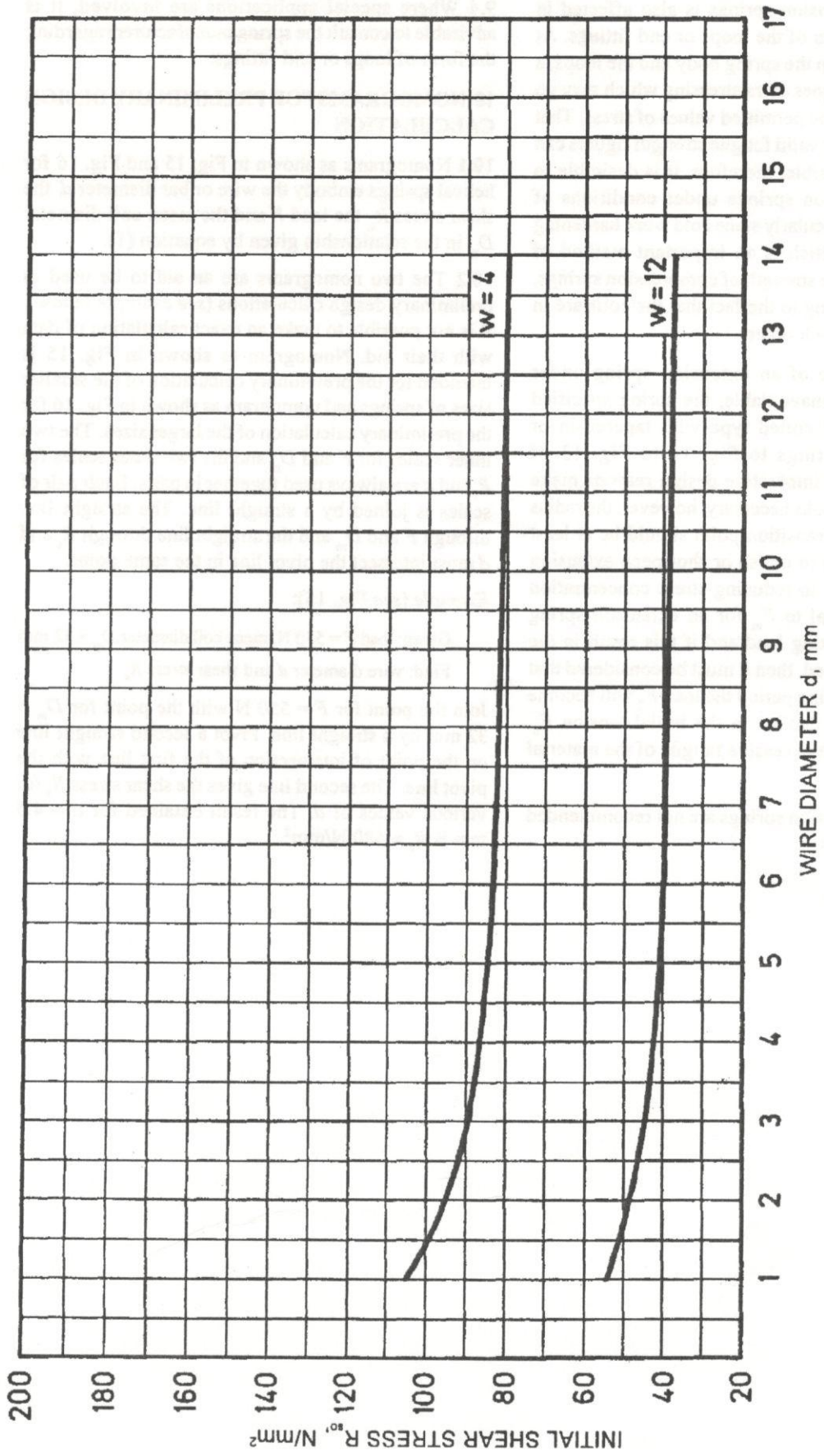

FIG. 14 AUTOMATIC COILING — APPROXIMATE VALUES OF PERMISSIBLE INITIAL SHEAR STRESS R_{60} FOR COLD COILED EXTENSION SPRINGS MADE FROM OIL HARDENED AND TEMPERED SPRING STEEL WIRES — UNALLOYED GRADE SW TO IS 4454 (Part 2)

9.2 The life of extension springs is also affected in particular by the form of the loops or end fittings. At the transition between the spring body and the loops, a loaded spring undergoes extra stressing which may go considerably above the permitted values of stress. That is why no universally valid fatigue strength figures can be given. When possible, therefore, it is desirable to avoid using extension springs under conditions of alternating load, particularly since cold work hardening by shot peening, which is an important method of increasing the fatigue strength of compression springs, is impracticable owing to the fact that the coils are in close contact with each other.

9.2.1 When the use of an extension spring under alternating load is unavoidable, the spring specified may be of the cold coiled type with tapered-in or screwed-in end fittings to Fig. 10 to Fig. 13 of IS 7907 (Part 2). If imperative design reasons make the use of loops or hooks necessary, however, the radius of curvature at the transition point should be at least $1.5 d$. It is advisable to polish or shot-peen extension springs with a view to reducing stress concentration points. If F_2 is equal to F_m for an extension spring subjected to alternating load and if this result in the limit R_{sp} being reached, then it must be considered that after a certain operating period the load F_2 will become smaller owing to a decline in the initial tension F_0 . Even failure through excessive fatigue of the material is not ruled out.

9.3 Hot coiled extension springs are not recommended for alternating loads.

9.4 Where special applications are involved, it is advisable to consult the spring manufacturer regarding the form of loops or end fittings.

10 NOMOGRAMS FOR PRELIMINARY DESIGN CALCULATION

10.1 Nomograms as shown in Fig. 15 and Fig. 16 for helical springs embody the wire or bar diameter d , the shear stress R_s , the load F and the mean coil diameter D_m in the relationship given by equation (1).

10.2 The two nomograms are an aid to be used in preliminary design calculations (see example below). It is not possible to make an exact calculation of data with their aid. Nomogram as shown in Fig. 15 is intended for the preliminary calculation of the smaller sizes of springs and nomogram as shown in Fig. 16 for the preliminary calculation of the larger sizes. The two inner scales for F and D_m and the two outer scales for R_s and d are always used together in pairs. Each pair of scales is joined by a straight line. The straight line through F and D_m and the straight line through R_s and d must intersect the pivot line in the same point.

Example (see Fig. 15):

Given: load $F = 550$ N, mean coil diameter $D_m = 32$ mm

Find: wire diameter d and shear stress R_s

Join the point for $F = 550$ N with the point for $D_m = 32$ mm by a straight line. Pivot a second straight line on the point of intersection of the first line with the pivot line. The second line gives the shear stress R_s for various values of d . The result obtained for $d \approx 4.5$ mm is $R_s \approx 480$ N/mm².



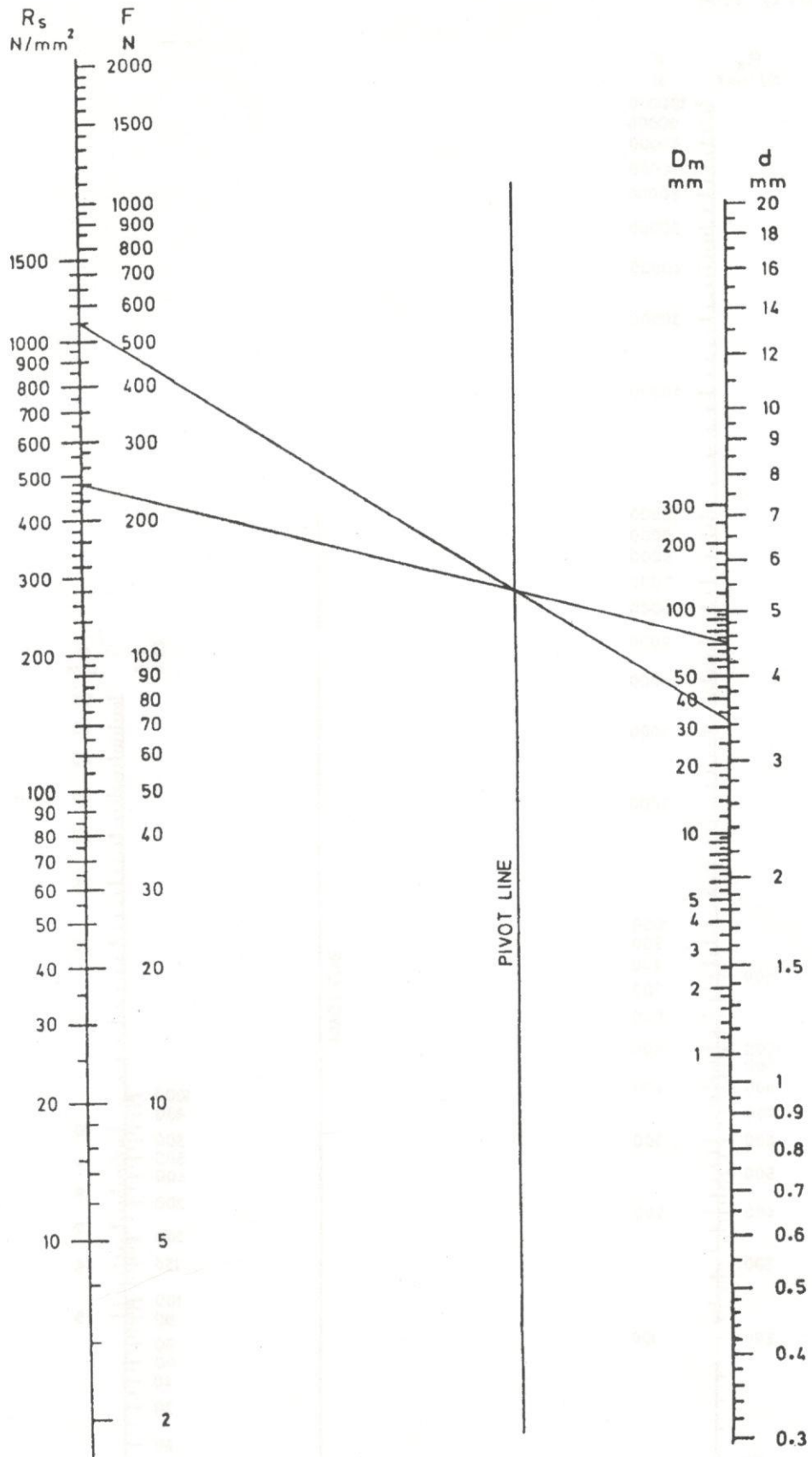

FIG. 15 NOMOGRAM FOR PRELIMINARY DESIGN CALCULATIONS OF SMALL SIZE SPRINGS

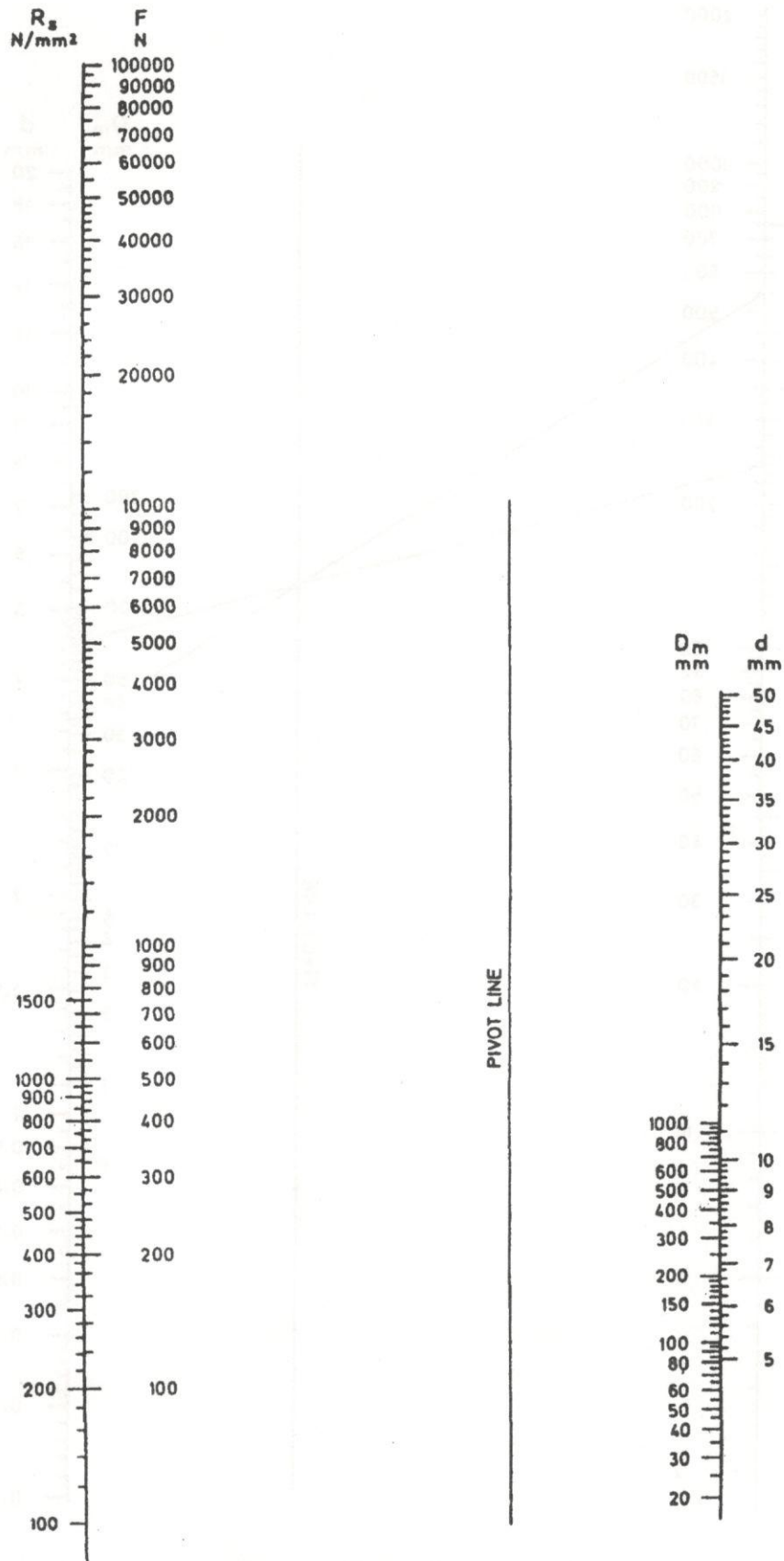

FIG. 16 NOMOGRAM FOR PRELIMINARY DESIGN CALCULATIONS OF LARGE SIZE SPRINGS

ANNEX A

(Clause 8.3.5)

EXAMPLES OF SPRING DESIGN CALCULATIONS

A-1 CALCULATION OF A COLD COILED EXTENSION SPRING SUBJECT TO A STATIC OR IN FREQUENTLY VARYING LOAD AND WITH INITIAL TENSION

An extension spring is required with Form B loops to Fig. 3 of IS 7907 (Part 2), for a load $F_1 = 250$ N at a deflection $f_1 = 30$ mm and a spring length $L_1 \approx 180$ mm. The spring shall permit a further stroke of approximately 65 mm without the load $F_2 = F_m$ exceeding 550 N. The space available admits an outside diameter of coil D_o of not more than 40 mm. It is thus necessary to determine the requisite spring data, that is $d, L_o, L_k, i_f, F_o, R_{s0}, R_{s1}, R_{s2}$ and the spring material.

A-1.1 Wire Diameter, d

From Equation (5):

$$d = \sqrt[3]{\frac{8 \times F \times D_m}{\pi R_s}} = \sqrt[3]{\frac{8 \times F_m \times D_m}{\pi R_{sp}}}$$

In Equation (5) R_s has to be replaced by the permissible shear stress R_{sp} the values of which can be taken from Fig. 4 to Fig. 6. It can be found by trial and error from the nomogram (see 10) as follows:

Using the nomogram as shown in Fig. 15 draw a straight line joining the maximum load; $F_m = F_2 = 550$ N and the diameter $D_m = 32$ mm, being the value assumed on the basis of the available space. This line cuts the pivot line at a point which serves as a pivot for a second straight line. By rotating this second line coordinate values of the shear stress R_s and the diameter d can be found. Diameter $d = 4.5$ mm, for example, yields $R_s = 480$ N/mm². According to Fig. 4 spring steel wire of Grade 2 to IS 4454 (Part 1) having $R_{sp} = 660$ N/mm² is suitable for this purpose.

On using this value in the calculation, the following result is obtained:

$$d = \sqrt[3]{\frac{8 \times 550 \times 32}{\pi \times 660}} = 4.1 \text{ mm}$$

The next larger wire diameter to IS 4454 (Part 1) namely, $d = 4.25$ mm, is selected.

A-1.2 Length of the Unloaded Spring, L_o

$$L_o = L_1 - f_1 = 180 - 30 = 150 \text{ mm}$$

A-1.3 Body Length of the Unloaded Spring Subject to Initial Tension, L_k

From IS 7907 (Part 2) Fig. 3, it is seen that.

$$\begin{aligned} L_k &= L_o - 2 L_H = L_o - 2 \times 0.8 \times D_1 \\ D_1 &= D_m - d = 32 - 4.25 = 27.75 \text{ mm} \\ L_k &= 150 - 2 \times 0.8 \times 27.75 = 105.6 \text{ mm} \end{aligned}$$

A-1.4 Number of Working Coils, i_t

According to 5.4, $i_f = i_t$ for extension springs with open loops. Using Equation (8):

$$i_t = i_f = \frac{L_k}{d} - 1$$

$$i_t = \frac{105.6}{4.25} - 1 = 24$$

A-1.5 Initial Tension, F_o

From Equation (13):

$$F_o = F - \frac{G \times d^4 \times f}{8 \times (D_m)^3 \times i_t}$$

Since F_1 and f_1 are given, these values are inserted for F and f .

$$F_o = F_1 - \frac{G \times d^4 \times f_1}{8 \times (D_m)^3 \times i_t}$$

Putting $G = 81\,370$ N/mm² (according to 5.9) gives:

$$F_o = 250 - \frac{81\,370 \times (4.25)^4 \times 30}{8 \times (32)^3 \times 24} = 128.8 \text{ N}$$

A-1.6 Deflection, f_2

From Fig. 1 the following relationship is derived:

$$\frac{F_1 - F_o}{f_1} = \frac{F_2 - F_o}{f_2}$$

$$\text{Hence } f_2 = \frac{F_2 - F_o}{F_1 - F_o} \times f_1$$

$$f_2 = \frac{550 - 128.8}{250 - 128.8} \times 30 = 100.4 \text{ mm}$$

IS 7907 (Part 1) : 2004

A-1.7 Length, L_2

$$L_2 = f_2 + L_0 \\ = 100.4 + 150 = 250.4 \text{ mm}$$

The stroke between L_1 and L_2 is $L_2 - L_1 = 250.4 - 180 = 70.4 \text{ mm}$

A-1.8 Coil Ratio, W

$$W = \frac{D_m}{d} = \frac{32}{4.25} = 7.53$$

A-1.9 Checking the Initial Shear Stress, R_{s0}

From Equation (1):

$$R_{s0} = \frac{8 \times D_m \times F_0}{\pi d^3} \\ R_{s0} = \frac{8 \times 32}{\pi (4.25)^3} \times 128.8 = 134.5 \text{ N/mm}^2$$

For spring steel wire of Grade 2 to IS 4454 (Part 1), Fig. 9 gives a value of approximately 135 N/mm² as permissible for R_{s0} (obtained by interpolating between

the curves for $w = 4$ and $w = 12$) assuming hand coiling with $w = 7.5$ and $d = 4.25 \text{ mm}$.

A-1.10 Checking the Shear Stresses R_{s1} and R_{s2}

$$R_s = \frac{8 \times D_m \times F}{\pi d^3} = \frac{8 \times 32}{\pi (4.25)^3} \times F = 1.06 F$$

$$R_{s1} = 1.06 \times F_1 \\ = 1.06 \times 250 = 265 \text{ N/mm}^2$$

$$R_{s2} = 1.06 \times F_2 \\ = 1.06 \times 550 = 583 \text{ N/mm}^2$$

The above values are permitted by Fig. 4 ($R_{sp} \approx 670 \text{ N/mm}^2$).

The first calculation performed does not always yield the desired and permitted results. In such cases the calculation must be repeated by starting from different assumptions.

A-1.11 Summary of Spring Data

The data comprising the spring specifications shall be entered in the form according to IS 7907 (Part 3).

ANNEX B*(Foreword)***COMMITTEE COMPOSITION****Automotive Springs and Suspension Sectional Committee, TED 21**

<i>Organization</i>	<i>Representative(s)</i>
Tata Motors Ltd, Jamshedpur	SHRI A. G. PRADHAN (<i>Chairman</i>) SHRI K. GOPALAKRISHNA (<i>Alternate</i>)
Akal Springs Pvt Ltd, Ludhiana	GENERAL MANAGER
All India Springs Manufacturers Association, Mumbai	SHRI A. A. MIRCHANDANI
Ashok Leyland Ltd, Chennai	SHRI APPALARAJU SHRI U. JAIKRISHNA (<i>Alternate</i>)
Association of State Road Transport Undertakings, New Delhi	SHRI A. S. LAKRA SHRI P. M. PHATE (<i>Alternate</i>)
Central Institute of Road Transport, Pune	SHRI N. R. KACHARE SHRI P. S. MUNOLI (<i>Alternate</i>)
Central Mechanical Engineering Research Institute, Durgapur	DR J. BASU DR T. K. PAUL (<i>Alternate</i>)
Conventry Springs & Engineering Co Pvt Ltd, Kolkata	SHRI A. BAFNA SHRI A. S. KOHLI (<i>Alternate</i>)
CQA (OFV) Vehicle Factory, Jabal Pur	GENERAL MANAGER
Gabriel India Ltd, Mumbai	SHRI K. SUNDARARAMAN SHRI S. K. BHAUMICK (<i>Alternate</i>)
Jai Parabolic Springs Ltd, Chandigarh	SHRI SUNIL HAROLIYA
Jamna Auto Industries Ltd, Yamuna Nagar	SHRI D. S. GILL SHRI B. K. KHANDELWAL (<i>Alternate</i>)
Kemen Springs Pvt Ltd, Mumbai	SHRI P. K. MIRCHANDANI
Mack Springs Pvt Ltd, Thane	SHRI D. V. SHARMA
Mahindra & Mahindra Ltd, Nashik	SHRI RAVINDRA DESHMUKH SHRI KAILASH JAT (<i>Alternate</i>)
Maruti Udyog Ltd, Gurgaon	SHRI D. N. DAVE SHRI G. VIJAYAN (<i>Alternate</i>)
Ministry of Heavy Industry & Public Enterprises, New Delhi	SHRI S. K. BHARIJ SHRI R. K. TRIPATHI (<i>Alternate</i>)
Research Designs & Standards Organization, Lucknow	JOINT DIRECTOR (STANDARDS) ASSISTANT DESIGN ENGINEER
Stumpp, Schuele & Somappa Pvt Ltd, Bangalore	SHRI B. S. MOOKHERJEE SHRI N. C. SRINIVASAN (<i>Alternate</i>)
The Automotive Research Association of India, Pune	SHRI S. RAJU
Upper India Steel Manufacturing & Engineering Co Ltd, Ludhiana	SHRI R. P. ENGIRA
Vehicle Factory, Jabalpur	SHRI M. K. MISHRA SHRI R. LODWAL (<i>Alternate</i>)
BIS Directorate General	SHRI K. K. VASHISTHA, Director & Head (TED) [Representing Director General (<i>Ex-officio</i>)]

Member Secretary
SHRI P. K. SHARMA
Director (TED), BIS

(Continued from second cover)

If the shear stresses occurring in the spring remain below the permissible range of stress or below the fatigue strength values in the case of springs subjected to alternating load, the spring will not fail due to fatigue within the envisaged life.

The permissible shear stresses and initial shear stress figures for cold coiled springs have been included for spring materials meeting general requirements.

In the preparation of this standard considerable assistance has been derived from DIN 2089 (Part 2) : 1992 'Design of cold or hot formed helical extension springs' issued by Deutsches Institut für Normung (DIN).

The composition of the Committee responsible for the formulation of this standard is given at Annex B.

In this standard the unit of force used is Newton (N) and that for stress is N/mm^2 :

1 kgf = 9.806 65 N (exactly)

or 1 kgf \approx 9.81 N (approximately)

\approx 10 N (within 2 percent error)

1 N/mm^2 = 1 MN/m^2

= 1 MPa [1 pascal (Pa) = $1\text{N}/\text{m}^2$]

\approx 0.1 kgf / mm^2 (within 2 percent error).

For the purpose of deciding whether a particular requirement of this standard is complied with, the final value, observed or calculated, expressing the result of a test or analysis, shall be rounded off in accordance with IS 2 : 1960 'Rules for rounding off numerical values (*revised*)'. The number of significant places retained in the rounded off value should be the same as that of the specified value in this standard.

Bureau of Indian Standards

BIS is a statutory institution established under the *Bureau of Indian Standards Act, 1986* to promote harmonious development of the activities of standardization, marking and quality certification of goods and attending to connected matters in the country.

Copyright

BIS has the copyright of all its publications. No part of these publications may be reproduced in any form without the prior permission in writing of BIS. This does not preclude the free use, in the course of implementing the standard, of necessary details, such as symbols and sizes, type or grade designations. Enquiries relating to copyright be addressed to the Director (Publication), BIS.

Review of Indian Standards

Amendments are issued to standards as the need arises on the basis of comments. Standards are also reviewed periodically; a standard along with amendments is reaffirmed when such review indicates that no changes are needed; if the review indicates that changes are needed, it is taken up for revision. Users of Indian Standards should ascertain that they are in possession of the latest amendments or edition by referring to the latest issue of 'BIS Catalogue' and 'Standards: Monthly Additions'.

This Indian Standard has been developed from Doc: No. TED 21 (341).

Amendments Issued Since Publication

Amend No.	Date of Issue	Text Affected

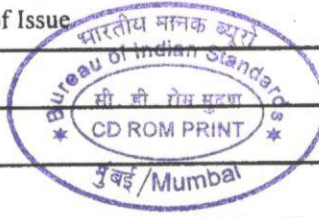

BUREAU OF INDIAN STANDARDS

Headquarters:

Manak Bhavan, 9 Bahadur Shah Zafar Marg, New Delhi 110002

Telephones: 2323 0131, 2323 3375, 2323 9402

website : www.bis.org.in

Regional Offices:

	Telephones
Central : Manak Bhavan, 9 Bahadur Shah Zafar Marg NEW DELHI 110002	{ 2323 7617 2323 3841
Eastern : 1/14 C.I.T. Scheme VII M, V.I.P. Road, Kankurgachi KOLKATA 700054	{ 2337 8499, 2337 8561 2337 8626, 2337 9120
Northern : SCO 335-336, Sector 34-A, CHANDIGARH 160022	{ 260 3843 260 9285
Southern : C.I.T. Campus, IV Cross Road, CHENNAI 600113	{ 2254 1216, 2254 1442 2254 2519, 2254 2315
Western : Manakalaya, E9 MIDC, Marol, Andheri (East) MUMBAI 400093	{ 2832 9295, 2832 7858 2832 7891, 2832 7892
Branches : AHMEDABAD. BANGALORE. BHOPAL. BHUBANESHWAR. COIMBATORE. FARIDABAD. GHAZIABAD. GUWAHATI. HYDERABAD. JAIPUR. KANPUR. LUCKNOW. NAGPUR. NALAGARH. PATNA. PUNE. RAJKOT. THIRUVANANTHAPURAM. VISAKHAPATNAM.	