

MASTER COPY

2008  
पुनर्पत्र 2003  
RE-AFFIRMED 2014  
2014

IS 2102 ( Part 2 ) : 1993  
ISO 2768-2 : 1989  
( Reaffirmed 1998 )

भारतीय मानक

सामान्य छूटें

भाग 2 पृथक-पृथक छूट अंकनों के बिना आकृतियों की ज्योमितीय छूटें

Indian Standard

GENERAL TOLERANCES

PART 2 GEOMETRICAL TOLERANCES FOR FEATURES WITHOUT INDIVIDUAL TOLERANCE INDICATIONS

( Third Reprint JUNE 2000 )

UDC 621.753.1 : 744.4



© BIS 1993

BUREAU OF INDIAN STANDARDS  
MANAK BHAVAN, 9 BAHADUR SHAH ZAFAR MARG  
NEW DELHI 110002

March 1993

Price Group 4



### NATIONAL FOREWORD

This Indian Standard ( Part 2 ) which is identical with ISO 2768-2 : 1989 'General tolerances — Part 2 : Geometrical tolerances for features without individual tolerance indications' was adopted by the Bureau of Indian Standards on the recommendations of the Engineering Standards Sectional Committee ( LM 01 ) and approval of the Light Mechanical Engineering Division Council.

General geometrical tolerances apply to all geometrical tolerance characteristics excluding cylindricity, profile of any line, profile of any surface, angularity, co-axiality, positional tolerances and total run. The standard specifies general geometrical tolerances for three tolerance classes. This standard is also intended to simplify drawing indication

In the adopted standard certain terminology and conventions are not identical with those used in the Indian Standard, attention is especially drawn to the following:

- a) Comma ( , ) has been used as a decimal marker while in Indian Standards, the current practice is to use point ( . ) as the decimal marker.
- b) Wherever the words 'International Standard' appear, referring to this standard, they shall be read as 'Indian Standard'.

In the adopted standard reference appears to certain international standards for which Indian Standards also exists. The corresponding Indian Standards which are to be substituted in their place are listed below along with their degree of equivalence for the editions indicated:

<i>International Standard</i>	<i>Corresponding Indian Standard</i>	<i>Degree of equivalence</i>
ISO 1101-1983	IS 8000 ( Part 1 ) : 1985 Geometrical tolerance on technical drawings : Part 1 Tolerances of form orientation, location and run-out and appropriate geometrical definitions ( <i>first revision</i> )	Identical
ISO 2768-1 : 1989	IS 2102 ( Part 1 ) : 1993 General tolerances : Part 1 Tolerances for linear and angular dimensions without individual tolerance indications ( <i>third revision</i> )	Identical
ISO 5459 : 1981	IS 10721 : 1983 Datum and datum systems for geometrical tolerancing on technical drawings	Identical
ISO 8015 : 1985	IS 12160 : 1987 Technical drawings — Fundamental tolerancing principles	Identical

BUREAU OF INDIAN STANDARDS  
MANAK BHAVAN, 2 BARABAT SHAH ZADAT MARG  
NEW DELHI 110002



# Indian Standard

## GENERAL TOLERANCES

### PART 2 GEOMETRICAL TOLERANCES FOR FEATURES WITHOUT INDIVIDUAL TOLERANCE INDICATIONS

Tolerance Class	Linear Dimensions		Angular Dimensions	
	mm	mm	mm	mm
H	0.1	0.05	0.05	0.05
K	0.05	0.025	0.025	0.025
F	0.025	0.0125	0.0125	0.0125

#### 1 Scope

This part of ISO 2768 is intended to simplify drawing indications and specifies general geometrical tolerances to control those features on the drawing which have no respective individual indication. It specifies general geometrical tolerances in three tolerance classes.

This part of ISO 2768 mainly applies to features which are produced by removal of material. Its application to features manufactured by other processes is possible; however, special examination is required to ascertain whether the customary workshop accuracy lies within the general geometrical tolerances specified in this part of ISO 2768.

#### 2 General

When selecting the tolerance class, the respective customary workshop accuracy has to be taken into consideration. If smaller geometrical tolerances are required or larger geometrical tolerances are permissible and more economical for any individual feature, such tolerances should be indicated directly in accordance with ISO 1101 (see clause A.2).

General geometrical tolerances in accordance with this part of ISO 2768 apply when drawings or associated specifications refer to this part of ISO 2768 in accordance with clause 6. They apply to features which do not have respective individual geometrical tolerance indications.

General geometrical tolerances apply to all geometrical tolerance characteristics, excluding cylindricity, profile of any line, profile of any surface, angularity, coaxiality, positional tolerances and total run-out.

In any event, general geometrical tolerances in accordance with this part of ISO 2768 should be used when the fundamental tolerancing principle in accordance with ISO 8015 is used and indicated on the drawing (see clause B.1).

#### 3 Normative references

The following standards contain provisions which, through reference in this text, constitute provisions of this part of

ISO 2768. At the time of publication, the editions indicated were valid. All standards are subject to revision, and parties to agreements based on this part of ISO 2768 are encouraged to investigate the possibility of applying the most recent editions of the standards indicated below. Members of IEC and ISO maintain registers of currently valid International Standards.

ISO 1101 : 1983, *Technical drawings — Geometrical tolerancing — Tolerancing of form, orientation, location and run-out — Generalities, definitions, symbols, indications on drawings.*

ISO 2768-1 : 1989, *General tolerances — Part 1: Tolerances for linear and angular dimensions without individual tolerance indications.*

ISO 5459 : 1981, *Technical drawings — Geometrical tolerancing — Datums and datum-systems for geometrical tolerances.*

ISO 8015 : 1985, *Technical drawings — Fundamental tolerancing principle.*

#### 4 Definitions

For the purposes of this part of ISO 2768, the definitions for geometrical tolerances given in ISO 1101 and ISO 5459 apply.

#### 5 General geometrical tolerances

(see also clause B.1)

##### 5.1 Tolerances for single features

###### 5.1.1 Straightness and flatness

The general tolerances on straightness and flatness are given in table 1. When a tolerance is selected from table 1, it shall be based, in the case of straightness, on the length of the corresponding line and, in the case of flatness, on the longer lateral length of the surface, or the diameter of the circular surface.



Table 1 — General tolerances on straightness and flatness

Values in millimetres

Tolerance class	Straightness and flatness tolerances for ranges of nominal lengths					
	up to 10	over 10 up to 30	over 30 up to 100	over 100 up to 300	over 300 up to 1 000	over 1 000 up to 3 000
H	0,02	0,05	0,1	0,2	0,3	0,4
K	0,05	0,1	0,2	0,4	0,6	0,8
L	0,1	0,2	0,4	0,8	1,2	1,6

### 5.1.2 Circularity

The general tolerance on circularity is equal to the numerical value of the diameter tolerance, but in no case shall it be greater than the respective tolerance value for circular radial run-out given in table 4 (see examples in clause B.2).

### 5.1.3 Cylindricity

General tolerances on cylindricity are not specified.

#### NOTES

1 The cylindricity deviation comprises three components: circularity deviation, straightness deviation and parallelism deviation of opposite generator lines. Each of these components is controlled by its individually indicated or its general tolerance.

2 If, for functional reasons, the cylindricity deviation has to be smaller than the combined effect (see clause B.3) of the general tolerances on circularity, straightness and parallelism, an individual cylindricity tolerance in accordance with ISO 1101 should be indicated for the feature concerned.

Sometimes, e.g. in the case of a fit, the indication of the envelope requirement (E) is appropriate.

## 5.2 Tolerances for related features

### 5.2.1 General

The tolerances specified in 5.2.2 to 5.2.6 apply to all features which are in relation to one another and which have no respective individual indication.

### 5.2.2 Parallelism

The general tolerance on parallelism is equal to the numerical value of the size tolerance or the flatness/straightness tolerance, whichever is the greater. The longer of the two features shall be taken as the datum; if the features are of equal nominal length, either may be taken as the datum (see clause B.4).

### 5.2.3 Perpendicularity

The general tolerances on perpendicularity are given in table 2. The longer of the two sides forming the right angle shall be taken as the datum; if the sides are of equal nominal length, either may be taken as the datum.

Table 2 — General tolerances on perpendicularity

Values in millimetres

Tolerance class	Perpendicularity tolerances for ranges of nominal lengths of the shorter side			
	up to 100	over 100 up to 300	over 300 up to 1 000	over 1 000 up to 3 000
H	0,2	0,3	0,4	0,5
K	0,4	0,6	0,8	1
L	0,6	1	1,5	2

### 5.2.4 Symmetry

The general tolerances on symmetry are given in table 3. The longer of the two features shall be taken as the datum; if the features are of equal nominal length, either may be taken as the datum.

NOTE — The general tolerances on symmetry apply where

- at least one of the two features has a median plane, or
- the axes of the two features are perpendicular to each other.

See examples in clause B.5.

Table 3 — General tolerances on symmetry

Values in millimetres

Tolerance class	Symmetry tolerances for ranges of nominal lengths			
	up to 100	over 100 up to 300	over 300 up to 1 000	over 1 000 up to 3 000
H	0,5			
K	0,6		0,8	1
L	0,6	1	1,5	2

### 5.2.5 Coaxiality

General tolerances on coaxiality are not specified.

NOTE — The deviation in coaxiality may, in an extreme case, be as great as the tolerance value for circular radial run-out given in table 4, since the deviation in radial run-out comprises the deviation in coaxiality and the deviation in circularity.

### 5.2.6 Circular run-out

The general tolerances on circular run-out (radial, axial and any surface of revolution) are given in table 4.

For general tolerances on circular run-out, the bearing surfaces shall be taken as the datum if they are designated as such. Otherwise, for circular radial run-out, the longer of the two features shall be taken as the datum; if the features are of equal nominal length, either may be taken as the datum.

Table 4 — General tolerances on circular run-out

Values in millimetres

Tolerance class	Circular run-out tolerances
H	0,1
K	0,2
L	0,5

## 6 Indications on drawings

6.1 If general tolerances in accordance with this part of ISO 2768 shall apply in conjunction with the general tolerances in accordance with ISO 2768-1, the following information shall be indicated in or near the title block:

- "ISO 2768";
- the tolerance class in accordance with ISO 2768-1;
- the tolerance class in accordance with this part of ISO 2768.

### EXAMPLE

ISO 2768-mk

In this case the general tolerances for angular dimensions in accordance with ISO 2768-1 do not apply to right angles (90°), which are implied but not indicated, because this part of ISO 2768 specifies general tolerances on perpendicularity.

6.2 If the general dimensional tolerances (tolerance class m) shall not apply, the respective letter shall be omitted from the designation to be indicated on the drawing:

### EXAMPLE

ISO 2768-K

6.3 In cases where the envelope requirement (E) also applies to all single features of size<sup>1)</sup>, the designation "E" shall be added to the general designation specified in 6.1:

### EXAMPLE

ISO 2768-mK-E

NOTE — The envelope requirement (E) cannot apply to features with individually indicated straightness tolerances which are greater than their size tolerances, e.g. stock material.

## 7 Rejection

Unless otherwise stated, workpieces exceeding the general geometrical tolerance shall not lead to automatic rejection provided that the ability of the workpiece to function is not impaired (see clause A.4).

1) For the purposes of this part of ISO 2768, a single feature of size comprises a cylindrical surface or two parallel plane surfaces.

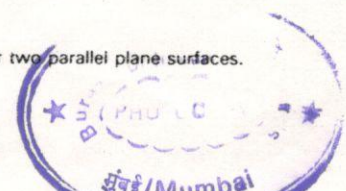

## Annex A (informative)

### Concepts behind general tolerancing of geometrical characteristics

**A.1** General tolerances should be indicated on the drawing by reference to this part of ISO 2768 in accordance with clause 6.

The values of general tolerances correspond to grades of customary workshop accuracy, the appropriate tolerance class being selected and indicated on the drawing.

**A.2** Above a certain tolerance value, which corresponds to the customary workshop accuracy, there is usually no gain in manufacturing economy by enlarging the tolerance. In any event, workshop machinery and the usual workmanship normally do not manufacture features with greater deviations. For example, a feature of 25 mm  $\pm$  0,1 mm diameter by 80 mm long manufactured in a workshop with a customary accuracy equal to or finer than ISO 2768-mH contains the geometrical deviations well within 0,1 mm for circularity, 0,1 mm for straightness of surface elements, and 0,1 mm for circular radial run-out (the values given have been taken from this part of ISO 2768). Specifying tolerances would be of no benefit in this particular workshop.

However, if, for functional reasons, a feature requires a smaller tolerance value than the "general tolerances", then that feature should have the smaller tolerance indicated individually adjacent to the particular feature. This type of tolerance falls outside the scope of general tolerances.

In cases where the function of a feature allows a geometrical tolerance equal to or larger than the general tolerance values, this should not be individually indicated, but should be stated on the drawing as described in clause 6. This type of tolerance allows full use of the concept of general geometrical tolerancing.

There will be "exceptions to the rule" where the function allows a larger tolerance than the general tolerances, and the larger tolerance will provide a gain in manufacturing economy. In these special cases, the larger geometrical tolerance should be indicated individually adjacent to the particular feature, e.g. the circularity tolerance of a large and thin ring.

**A.3** Using general geometrical tolerances leads to the following advantages:

- a) drawings are easier to read and thus communication is made more effective to the user of the drawing;

- b) the design draughtsman saves time by avoiding detailed tolerance calculations as it is sufficient only to know that the function allows a tolerance greater than or equal to the general tolerance;

- c) the drawing readily indicates which features can be produced by normal process capability, which also assists quality engineering by reducing inspection levels;

- d) those features remaining, which have individually indicated geometrical tolerances, will, for the most part, be those controlling features for which the function requires relatively small tolerances and which therefore may cause special effort in the production — this will be helpful for production planning and will assist quality control services in their analysis of inspection requirements;

- e) purchase and sub-contract supply engineers can negotiate orders more readily since the "customary workshop accuracy" is known before the contract is placed; this also avoids arguments on delivery between the buyer and the supplier, since in this respect the drawing is complete.

These advantages are fully obtained only when there is sufficient reliability that the general tolerances will not be exceeded, i.e. when the customary workshop accuracy of the particular workshop is equal to or finer than the general tolerances indicated in the drawing.

The workshop should, therefore,

- find out by measurements what its customary workshop accuracy is;
- accept only those drawings having general tolerances equal to or greater than its customary workshop accuracy;
- check by sampling that its customary workshop accuracy does not deteriorate.

Relying on undefined "good workmanship" with all its uncertainties and misunderstandings is no longer necessary with the concept of general geometrical tolerances. The general geometrical tolerances define the required accuracy of "good workmanship".

**A.4** The tolerance the function allows is often greater than the general tolerance. The function of the part is, therefore, not always impaired when the general tolerance is (occasionally) exceeded at any feature of the workpiece. Exceeding the general tolerance should lead to a rejection of the workpiece only if the function is impaired.

**Annex B**  
 (informative)

**Further information**

**B.1 General geometrical tolerances**  
 (see clause 5)

According to the principle of independency (see ISO 8015), general geometrical tolerances apply independently of the actual local size of the workpiece features. Accordingly, the

general geometrical tolerances may be used even if the features are everywhere at their maximum material size (see figure B.1).

If the envelope requirement (E) is individually indicated adjacent to the feature or generally to all features of size as described in clause 6, this requirement should also be complied with.

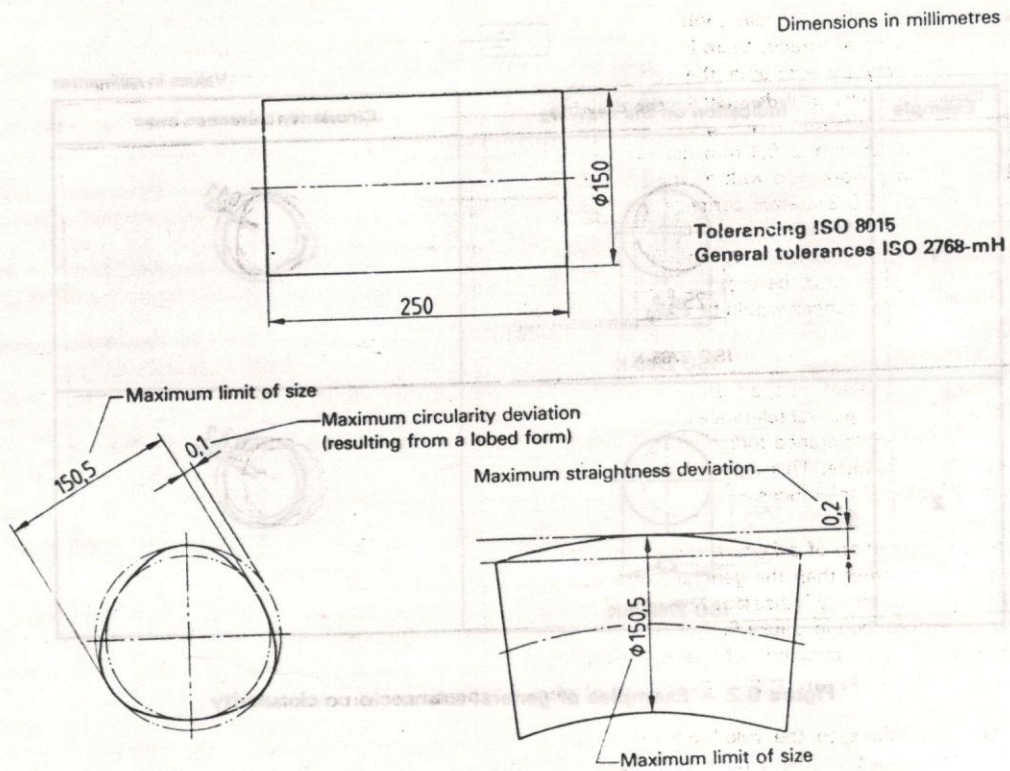

**Figure B.1 — Principle of independency; maximum permissible deviations on the same feature**

**B.2 Circularity** (see 5.1.2) — Examples

**EXAMPLE 1** (see figure B.2)

The permissible deviation of the diameter is indicated directly on the drawing; the general tolerance on circularity is equal to the numerical value of the diameter tolerance.

**EXAMPLE 2** (see figure B.2)

The general tolerances in accordance with the indication ISO 2768-mK apply. The permissible deviations for the diameter of 25 mm are  $\pm 0,2$  mm. These deviations lead to the numerical value of 0,4 mm which is greater than the value of 0,2 mm given in table 4; the value of 0,2 mm, therefore, applies for the circularity tolerance.

**B.3 Cylindricity** (see note 2 in 5.1.3)

The combined effect of the general tolerances of circularity, straightness and parallelism is, for geometrical reasons, smaller than the sum of the three tolerances since there is also a certain limitation by the size tolerance. However, for the sake of simplicity, in order to decide whether the envelope requirement (E) or an individual cylindricity tolerance is to be indicated, the sum of the three tolerances can be taken into account.

**B.4 Parallelism** (see 5.2.2)

Depending on the shapes of the deviations of the features, the parallelism deviation is limited by the numerical value of the size tolerance (see figure B.3) or by the numerical value of the straightness or flatness tolerance (see figure B.4).

Values in millimetres





Example	Indication on the drawing	Circularity tolerance zone
1	 ISO 2768-K	
2	 ISO 2768-mK	

Figure B.2 — Examples of general tolerances on circularity

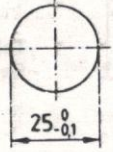
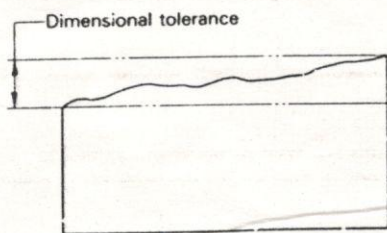

Figure B.3 — Parallelism deviation equal to the numerical value of the size tolerance

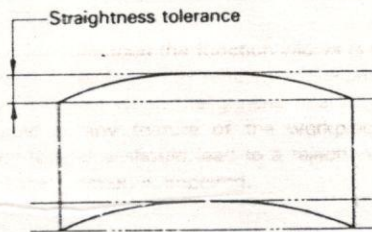
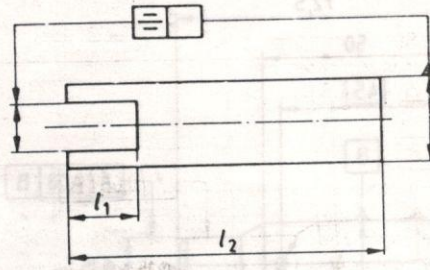

Figure B.4 — Parallelism deviation equal to the numerical value of the straightness tolerance





### B.5 Symmetry (see 5.2.4) — Examples



a) Datum: longer feature ( $l_2$ )

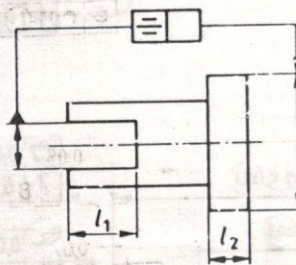

b) Datum: longer feature ( $l_1$ )

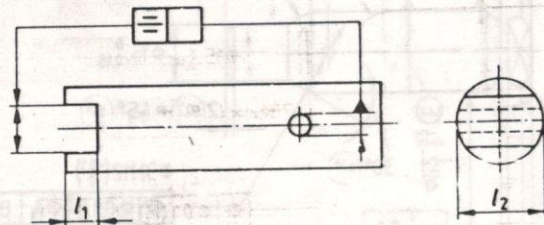

c) Datum: longer feature ( $l_2$ )

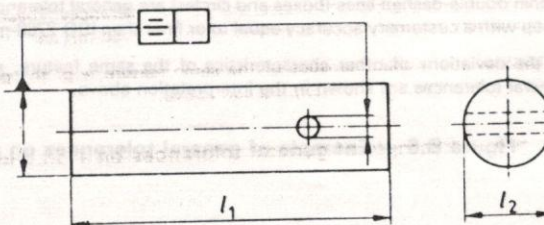

d) Datum: longer feature ( $l_1$ )

Figure B.5 — Examples of general tolerances on symmetry (datums specified in accordance with 5.2.4)



B.6 Example of a drawing

Indication on the drawing

Dimensions in millimetres

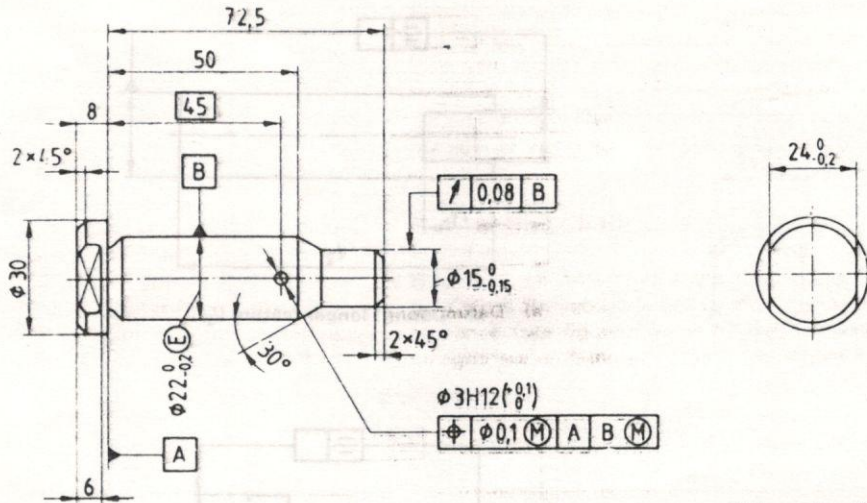

Interpretation

Tolerancing ISO 8015  
 General tolerances ISO 2768-mH

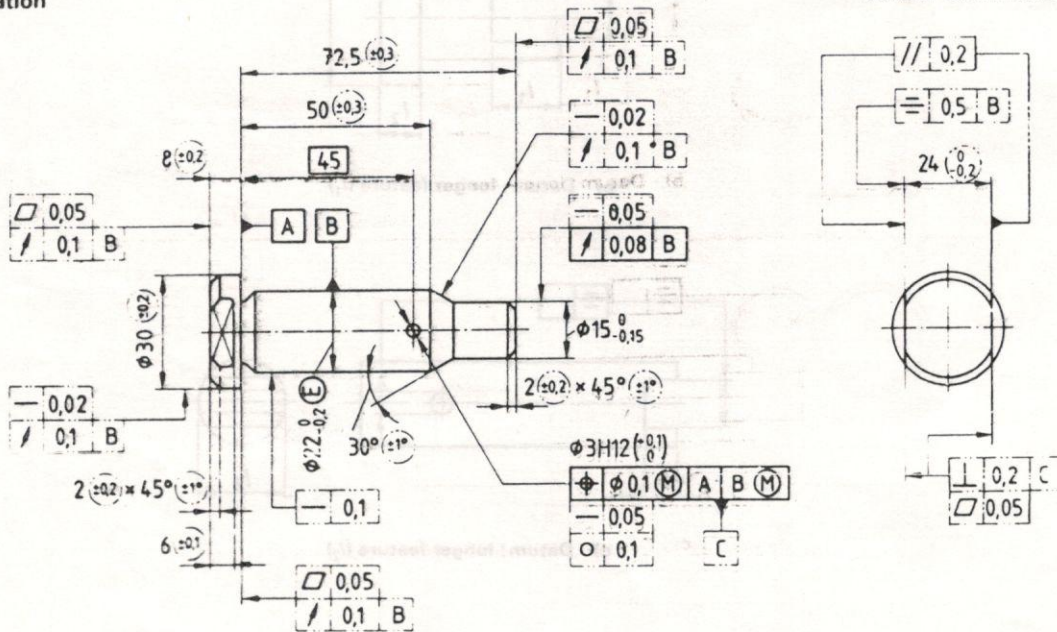

NOTES

- 1 The tolerances shown in chain thin double-dashed lines (boxes and circles) are general tolerances. These tolerance values would be automatically achieved by machining in a workshop with a customary accuracy equal to or finer than ISO 2768-mH and would not normally require to be inspected.
- 2 As some tolerances also limit the deviations of other characteristics of the same feature, e.g. the perpendicularity tolerance also limits the straightness deviations, not all general tolerances are shown in the interpretation above.

Figure B.6 — Example of general tolerances on a drawing



## Bureau of Indian Standards

BIS is a statutory institution established under the *Bureau of Indian Standards Act, 1986* to promote harmonious development of the activities of standardization, marking and quality certification of goods and attending to connected matters in the country.

### Copyright

BIS has the copyright of all its publications. No part of these publications may be reproduced in any form without the prior permission in writing of BIS. This does not preclude the free use, in the course of implementing the standard, of necessary details, such as symbols and sizes, type or grade designations. Enquiries relating to copyright be addressed to the Director (Publication), BIS

### Review of Indian Standards

Amendments are issued to standards as the need arises on the basis of comments. Standards are also reviewed periodically; a standard along with amendments is reaffirmed when such review indicates that no changes are needed; if the review indicates that changes are needed, it is taken up for revision. Users of Indian Standards should ascertain that they are in possession of the latest amendments or edition by referring to the latest issue of 'BIS Handbook' and 'Standards: Monthly Additions'.

This Indian Standard has been developed from Doc: No. LM 01 ( 3380 )

### Amendments Issued Since Publication

Amend No.	Date of Issue	Text Affected

## BUREAU OF INDIAN STANDARDS

### Headquarters:

Manak Bhavan, 9 Bahadur Shah Zafar Marg, New Delhi 110002  
Telephones: 323 01 31, 323 3375, 323 94 02

Telegrams: Manaksanstha  
(Common to all offices)

### Regional Offices:

Central : Manak Bhavan, 9 Bahadur Shah Zafar Marg  
NEW DELHI 110002

Telephone  
323 76 17, 323 38 41

Eastern : 1/14 C.I.T. Scheme VII M, V.I.P. Road, Kankurgachi  
CALCUTTA 700054

{ 337 84 99, 337 85 61  
{ 337 86 26, 337 91 20

Northern : SCO 335-336, Sector 34-A, CHANDIGARH 160022

{ 60 38 43  
{ 60 20 25

Southern : C.I.T. Campus, IV Cross Road, CHENNAI 600113

{ 235 02 16, 235 04 42  
{ 235 15 19, 235 23 15

Western : Manakalaya, E9 MIDC, Marol, Andheri (East)  
MUMBAI 400093

{ 832 92 95, 832 78 58  
{ 832 78 91, 832 78 92

Branches : AHMADABAD. BANGALORE. BHOPAL. BHUBANESHWAR.  
COIMBATORE. FARIDABAD. GHAZIABAD. GUWAHATI.  
HYDERABAD. JAIPUR. KANPUR. LUCKNOW. NAGPUR.  
PATNA. PUNE. RAJKOT. THIRUVANANTHAPURAM.

Printed at Simco Printing Press, Delhi

